

**MODEL**

**BCT 75-75 G  
BCT 100-95 G**

# **INSTALLATION AND USER INSTRUCTIONS**

**UNITED KINGDOM / IRELAND**

**HOT WATER STORAGE HEATERS**

Read these installation instructions first before installing the appliance. Carefully read the user instructions before igniting the appliance. Failure to follow these instructions may lead to risk of explosion and/or fire and could cause material damage and/or bodily harm.

Installation and commissioning should be carried out by a qualified competent installer. The type of gas and the value at which the appliance is set standard in the factory are registered on the rating plate. The appliance may only be installed in a room if this room meets the ventilation requirements.

**BSS GROUP PLC ACCEPTS NO RESPONSIBILITY FOR WARRANTY, SERVICE AND/OR PRODUCT LIABILITY IN CASE OF UNAUTHORIZED ALTERATIONS, PRODUCT MODIFICATIONS OR REPAIR.**

<b>1.</b>	<b>General</b> .....	4
1.1	Introduction .....	4
1.2	Technical safety equipment .....	6
1.2.1	Gas control block .....	6
1.2.2	Combustion products discharge safety device .....	6
1.3	Technical information .....	8
1.3.1	Dimensions .....	8
1.3.2	Technical data .....	10
<b>2.</b>	<b>For the installer</b> .....	11
2.1	Installation instructions .....	11
2.1.1	Installation .....	11
2.1.2	Water circulations system .....	11
2.1.3	Gas connection .....	12
2.1.4	Flue system .....	13
2.1.5	Draught diverter .....	13
2.2	Commissioning .....	14
2.2.1	Filling the water heater .....	14
2.2.2	Putting into operation .....	14
2.3	Pilot adjustment .....	15
2.4	Putting out of operation .....	15
2.5	Temperature regulation .....	15
2.6	Setting the nominal heat input .....	16
2.7	Conversion procedure .....	16
2.8	Maintenance .....	18
2.8.1	Sacrificial anode .....	18
2.8.2	Cleaning .....	19
2.8.3	Decalcification .....	19
2.8.4	Spare parts .....	19
2.9	Inlet combination .....	20
2.10	Fault finding .....	20
2.10.1	Safety thermostat .....	20
2.10.2	Flue down draught safety device .....	20
2.10.3	Hot water temperature too low .....	20
2.10.4	Hot water temperature too high .....	20
2.11	Gas smell .....	20
2.12	Condensation .....	20
<b>3.</b>	<b>For the user</b> .....	21
3.1	Commissioning .....	21
3.1.1	Filling the water heater .....	21
3.1.2	Putting into operation .....	21
3.1.3	Use .....	21
3.1.4	Putting out of operation .....	21
3.1.5	Maintenance .....	22
3.2	Fault finding .....	23
<b>4.</b>	<b>Warranty</b> .....	24

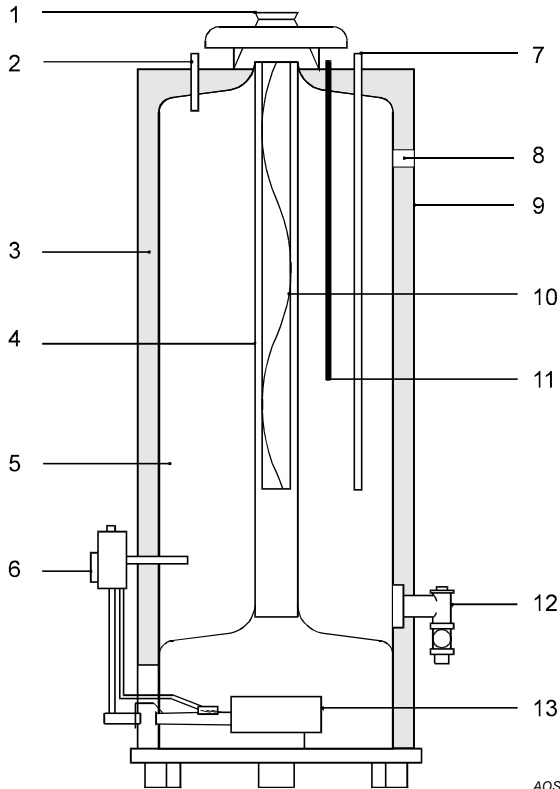

AOS 0489

Drawing 1 - Cross-section of the heater

- |                      |                          |
|----------------------|--------------------------|
| 1) Draught diverter  | 8) T&P safety connection |
| 2) Hot water outlet  | 9) Outer casting         |
| 3) Insulation        | 10) Flue baffle          |
| 4) Flue tube         | 11) Sacrificial anode    |
| 5) Glass lined tank  | 12) Drain tap            |
| 6) Gas control valve | 13) Atmospheric burner   |
| 7) Cold water inlet  |                          |

# 1. GENERAL

## 1.1 Description of the appliance

Construction of the water heater is in accordance with the European standard for gas heated water storage heaters for sanitary application (EN 89). The appliance thus meets the European Directory for Gas Appliances and is therefore entitled to carry the CE-marking. It is an open flued appliance without ventilator and with a flue gas down draught safeguard (category B11BS). The water heater is suitable for a maximum working pressure of 8 bar. The water-heater tank is manufactured from low carbon sheet steel and is glass-lined on the inside. In addition the tank is fitted with a sacrificial anode as an extra protection against corrosion. A thick PU-insulation layer covered in a steel jacket reduces unnecessary heat loss. When the appliance is filled with water it continuously is under water pressure. As hot water is drained from the tank, cold water is added immediately. A flue baffle has been placed in the flue tube to improve heat transfer. The flue gasses pass their heat on to the water by means of radiation and convection. The flue gasses are guided to the chimney via the draught diverter. The exhaust of the flue gasses is realized by natural thermal draught (see drawing 1).

Dead legs on a hot water installation are undesirable. Where possible they should be avoided. Where the inclusion on the system of a dead leg is unavoidable the following restrictions should be applied:

- for pipes not exceeding 19 mm. inside diameter; maximum length of dead leg permitted 12.0 metres;
- for pipes exceeding 19 mm. but not exceeding 25 mm. inside diameter; maximum length of dead leg 7.5 metres;

- for pipes with an inside diameter exceeding 25 mm. maximum dead leg 3.0 metres.

## 1.2 Technical safety equipment

### 1.2.1 Gas control valve

The water heater has been fitted with a gas control valve consisting of a thermo-electrical pilot flame safeguard, pilot flame pressure regulator, burner pressure regulator, a control thermostat (adjustable between 40°C and 81°C) and a safety thermostat (90°C). This gas control valve with its simple and secure control respectively switches the gas supply to the main burner on or off.

This gas control valve is suitable for gasses from the first, second and third gas family. The maximum inlet pressure is 50 mbar.

### 1.2.2 Combustion products discharge safety device

The water heater has been fitted with a combustion products discharge safety device. It is the function of the safety device to prevent flue gasses from the water heater entering the room where the water heater has been placed, instead of passing through the flue to outside atmosphere. The gas supply is disconnected as soon as the device is activated by hot gasses flowing over the sensor.

After the cause of the re-entry of flue gasses has been traced the device can be put back into operation by pressing its reset button.

If this failure occurs frequently, this indicates that the flue suffers from down draught conditions. It is recommended that a competent person carry out the necessary remedial action.

#### **Important**

**The combustion products discharge safety device should never be put out of operation. Re-entry of flue gasses to the building could be harmful and cause poisoning or death.**

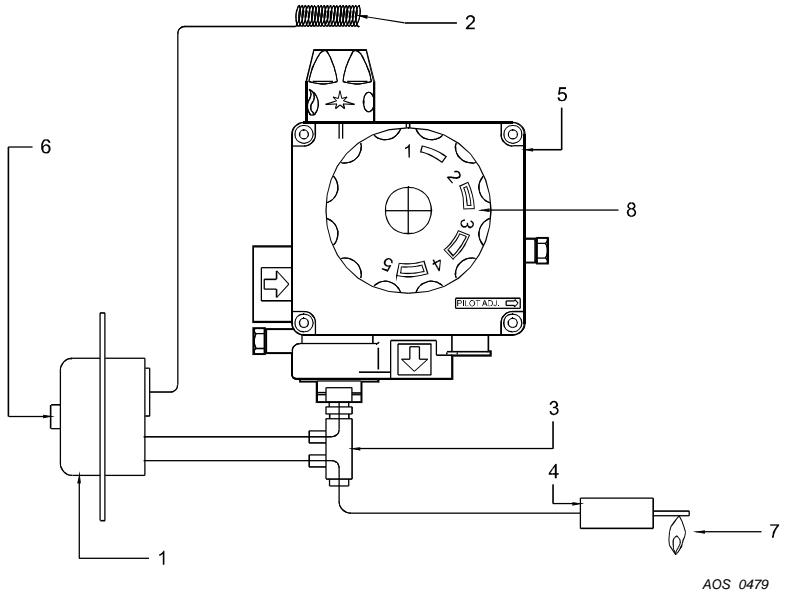

Figure 2 - Combustion products discharge safety device with gas control valve

- |  |                               |
|--|-------------------------------|
| 1) Combustion products discharge safety device thermostat        | 4) Thermocouple               |
| 2) Sensor Combustion products discharge safety device thermostat | 5) Gas control block          |
| 3) Thermocouple with built-in interrupter                        | 6) Reset button               |
|  | 7) Pilot burner               |
|  | 8) Temperature regulator knob |

### 1.3 Technical information

#### 1.3.1 Dimensions

These water heaters are only suitable for a flue tube with minimal the announced diameter (dimension G).

Dimensions	BCT 75-75	BCT 100-95
A	1585	1780
B	1450	1640
D	645	675
F	730	765
G	130	130
K	390	390
L	375	385
M	1505	1685
N	1505	1685
R	285	275
S	1280	1460
V	410	410
1	Cold water inlet	
2	Hot water outlet	
3	Gas control valve	
4	Drain tap	
5	T&P valve tapping	

All dimensions are given in mm. (rounded off on 5 mm)

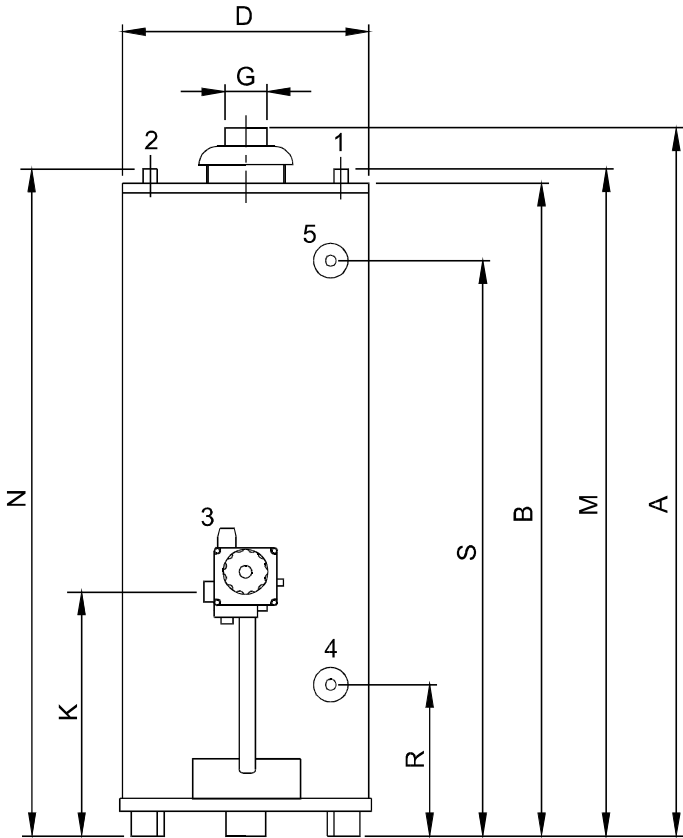
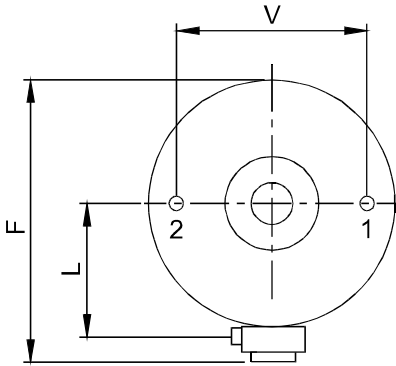

AOS 0554

Drawing 3 - Dimensions

### 1.3.2 Technical data

Device category: II2H3+

DESCRIPTION	unit	BCT 75-75	BCT 100-95
<b>DATA NATUREL GAS G20 - 20 mbar</b>			
Nominal load (gross)	kW	20.8	24.7
Nominal capacity	kW	16.0	18.3
Supply pressure	mbar	20	20
Burner pressure	mbar	11.5	10.0
Gas consumption*	m <sup>3</sup> /h	2.20	2.61
Diameter main orifice	mm	3.90	4.50
Diameter pilot orifice	mm	2x0.27	2x0.27
Heating time ΔT= 45K	min	56	61
<b>DATA BUTANE G30 - 28/30 mbar</b>			
Nominal load (gross)	kW	20.1	27.3
Supply pressure	mbar	30	30
Burner pressure	mbar	30	30
Gas consumption*	kg/h	1.59	2.15
Diameter main orifice	mm	2.20	2.50
Diameter pilot orifice	mm	2x0.16	2x0.16
<b>DATA PROPANE G31 - 37 mbar</b>			
Nominal load (gross)	kW	19.2	26.3
Supply pressure	mbar	37	37
Burner pressure	mbar	37	37
Gas consumption*	kg/h	1.49	2.04
Diameter main orifice	mm	2.20	2.50
Diameter pilot orifice	mm	2x0.16	2x0.16
<b>GENERAL</b>			
Storage capacity	litres	265	355
Water connections**	-	1"-14NPT	1¼"-14NPT
Gas connection	-	ISO <sup>7</sup> / <sub>1</sub> Rp <sup>1</sup> / <sub>2</sub>	ISO <sup>7</sup> / <sub>1</sub> Rp <sup>1</sup> / <sub>2</sub>
Drain valve	-	<sup>3</sup> / <sub>4</sub> "-14NPT	<sup>3</sup> / <sub>4</sub> "-14NPT
Anode	-	<sup>3</sup> / <sub>4</sub> "-14NPT	<sup>3</sup> / <sub>4</sub> "-14NPT
T&P plug	-	<sup>3</sup> / <sub>4</sub> "-14NPT	<sup>3</sup> / <sub>4</sub> "-14NPT
Maximum operating pressure	bar	8	8
Empty weight	kg	153	178

\* Gas consumption at 1013,25 mbar and 15 °C

\*\* For a leak proof sealed connection European coupling pieces can be used on the NPT connection nipples with a pipe thread of ISO 228/1

## 2. FOR THE INSTALLER

### 2.1 Installation instructions

This water heater must be fitted in a location which will permit the provision of an approved flue system and adequate ventilation.

A service clearance of 15 cm at the sides and rear of the unit and 60 cm at the front of the unit should be allowed for ease of servicing. Adequate distance must be allowed between the top of the unit and any obstruction or ceiling to allow the flue baffle and anode to be inspected, cleaned or in the case of the anode replaced if necessary.

The water heater must stand on a level surface resistant to heat and with sufficient strength to support the weight of the unit when full of water.

This water heater must **not** be installed in a bath room, bedroom or in a cupboard opening on to such rooms. This water heater must **not** be installed in any area where flammable materials are used or stored.

Insufficient ventilation may give rise to a risk of fire, explosion or suffocation. If in doubt consult the national and local regulations governing the installation of gas appliances or your local British gas service department.

#### 2.1.1 Installation

The installation of this water heater should be carried out by a suitably qualified competent person. It is a criminal offence for unqualified persons to install gas equipment.

Installation should be carried out in accordance with all local authority and building regulations, local water authority and fire regulations and the following British standards: 5440, 5546, 6644, 6700, 6798 and 6891.

Some chemicals produce vapours which can cause rapid failure of thermocouples, burners and storage tanks if they are drawn into the combustion air supply.

**Therefore if this water heater will be used to supply hot water to:**

- hairdressers,
- dry cleaners
- industrial degreasing processes or any other area where compounds containing halogens are used and stored, care should be taken that all primary and secondary air is drawn from outside atmosphere free of such contaminants.

For further advise contact BSS GROUP PLC.

#### 2.1.2 Water circulation system

BSS GROUP PLC are suitable for connection to vented, unvented and pumped pressurised systems. In each case appropriate valves and fittings should be used to ensure the system complies with the requirements of the water by laws, and appropriate building regulations.

When fitting it is essential the rules of 'good practice' are applied at all stages of installation.

#### Vented systems

If the water heater is to be connected to a cold feed tank or cistern the hot water supply pipe must include an open vent which discharges over the cold feed cistern. The cold feed cistern must have an actual capacity of greater volume than the hourly recovery rate of the water heater(s) which it supplies. The minimum actual capacity is 50 gallons or 227 litres.

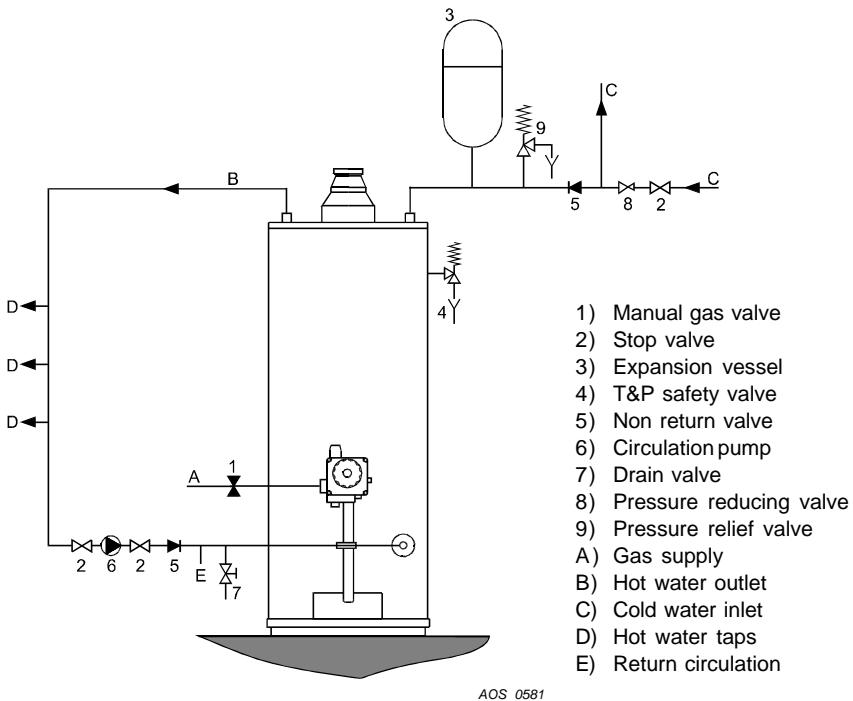

Drawing 4 - Connection diagram  
 (unvented system)

### Unvented

To install an BSS GROUP PLC on an unvented cold water supply system a kit of valves and fittings listed by the water research centre and complying with part G3 of the current building regulations should be used. Installation should be carried out generally as shown on the following diagram. See drawing 4.

BSS GROUP PLC are tested to a maximum pressure of 12 bar and a maximum working pressure of 8 bar.

### **2.1.3 Gas connection**

The gas supply to this appliance must be installed in accordance with BS 6891 (1988).

Fit the 1/2" gas supply cock supplied with this unit immediately before the gas control block. No heat or soldered joints should be applied in the vicinity of the gas control block, as they could cause damage to the control.

All connections and joints should be tested for gas soundness with a suitable leak detector (do not use a naked flame).

### 2.1.4 Flue system

The water heater should be fitted with a flue system connected to the draught diverter. The flue pipe should rise for at least 50 cm. vertically before the inclusion of any bends. If a horizontal run of flue is required this should be kept to the minimum length possible and incorporate a rise of 6 cm. per metre of run. A split clip or flange should be provided in the flue close to the draught diverter for ease of servicing.

All flue materials should be corrosion resistant i.e. stainless steel or galvanised and must include a tested and approved terminal to BS 5440 part 1. If the flue passes through any combustible material measures must be taken to protect against the possibility of fire.

All flues must terminate in free air space approx. 1.5 metres from any vertical surface of structure i.e. chimney stacks, roof parapets, etc. If an existing chimney or flue is to be used this should be swept clean and be free of debris before an approved liner is installed and connected to the water heater.

### 2.1.5 Draught diverter

The draught diverter, supplied separately in the delivery crate, **MUST** be fitted to the top of the heater in an unmodified condition before connecting the flue system.

The sensor of the combustion products discharge safety device is pre-fitted to the draught diverter so care should be taken not to damage the capillary and thermostat. With the sensor facing forward, place the draught diverter over the flue tube and ensure the three legs engage with the slots in the top casing.

To complete the installation of the combustion products discharge safety device, remove the two screws from the top casing, position the bracket with the pre-assembled thermostat over the holes and re-apply screws. Complete the electrical circuit by connecting the

two pin plug to its appropriate socket on the top casing. Should the safety device operate, the heater will shut down and only restart when the sensor temperature has dropped sufficiently for the button on the thermostat to be reset.

#### **Important**

**The combustion products discharge safety device should never be put out of operation. Re-entry of flue gases to the building could be harmful and cause poisoning or death.**

## 2.2 Commissioning

### 2.2.1 Filling the water heater

1. Close the drain tap.
2. Open the cold water tap to the water heater and open all taps where hot water can be drained for de-aeration. The water heater is filled as soon as cold water flows from all taps.
3. Close all hot water taps.

### 2.2.2 Putting into operation

1. Check whether the water-heater has been filled with water and whether the gas supply to the water heater is open;
2. Turn the temperature control knob clockwise and place the control knob in the 'PILOT'-position (\*);
3. Remove the outer door of the combustion chamber;
4. Keep the control knob pushed-in and press the piezo-ignitor several times until the pilot burns (see drawing 6);
5. Keep the control button (\*) pushed-in for approximately 20 seconds. After releasing the button the pilot should remain burning. If the pilot extinguishes you should wait 5 minutes before repeating the ignition procedure. The size of the pilot flame can be adjusted (see also "Pilot adjustment");
6. Fit the outer door;
7. Turn the control button to the 'ON' (⬇) position;
8. Place the temperature control button in the correct position, preferably position 3 (approximately 60°C). The appliance will now operate fully automatically.

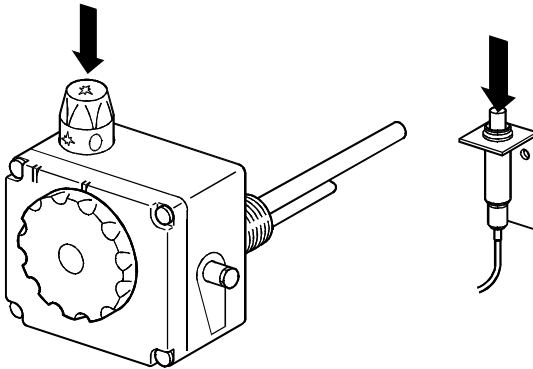

AOS 0484

Drawing 6 - Operation of the gas control block

## 2.3 Pilot adjustment

The pilot can be adjusted by means of the regulating screw under the plastic cover on the right hand side of the gas control block (see drawing 7).

Turn the screw clockwise to reduce the gas pressure and anti clockwise to increase the pressure. Care should be taken to ensure the pilot covers the thermocouple element correctly.

## 2.4 Putting out of operation

1. For short periods of time the control knob should be turned to (✱); the pilot keeps burning.
2. For longer periods of time the knob should be turned to the (●) position; the pilot is extinguished.
3. Close the gas tap in the supply pipe. In case of longer interruptions or in the event of risk of frost it is recommended to also close the cold water tap and to drain the appliance after cooling (open the drain tap; it is possible to connect a drain hose to the drain tap; open the nearest hot water drain point to prevent air locks). To be able to drain the appliance completely it should be disconnected and tilted slightly in the direction of the drain tap.

## 2.5 Temperature regulation

The appliance is under water supply pressure (maximum 8 bar). The amount of cold water that is added is equal to the amount of hot water used. The gas control block automatically regulates the gas supply. The main burner will ignite as soon as a reduction in water temperature is sensed by the thermostat. The main burner will shut down as soon as the preset temperature is achieved.

Position 1 = approximately 40°C

Position 2 = approximately 50°C

Position 3 = approximately 60°C

Position 4 = approximately 70°C

Position 5 = approximately 80°C

At high water temperatures there is more scale buildup in the appliance. It is for this reason that it is recommended to place the temperature control knob in position 3 as the accumulation of scale will be reduced. In addition a safety thermostat has been fitted. This thermostat completely shuts off the gas supply if the water temperature reaches 90°C, also extinguishing the pilot burner.

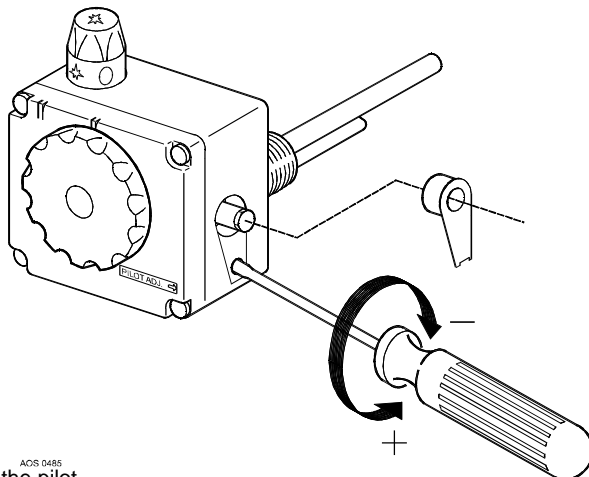

Drawing 7 - Setting the pilot

## 2.6 Setting the nominal heat input

The gas control has been factory preset to the water heater nominal heat input.

A further check of the burner pressure should be carried out during the commissioning of the unit after installation. The following procedure should be followed.

1. Remove the protruding cover screw on the right side of the gas control block and connect a U-gauge manometer to the outlet;
2. Put the appliance into operation and ignite the burner;
3. Check the burner pressure and, if necessary, reset by means of the adjusting screw "pr adj" (pressure adjustment; see drawing 8). To make this possible the temperature control

knob should be removed by pulling it straight forward, making the "pr adj" visible. Turning clockwise reduces the pressure; turning anti clockwise increases the pressure. It is recommended to check the heat input by means of the gas meter;

4. Turn off the appliance and remove the manometer hose and replace the adjusting screw;
5. Relace the thermostat control knob;
6. Put the appliance into operation.

## 2.7 Converting to another type of gas

For conversion of the appliance from natural gas to another type of gas, or vice versa, it is necessary to exchange the pilot injector and the main injector. The conversion may only be executed by a qualified competent person.

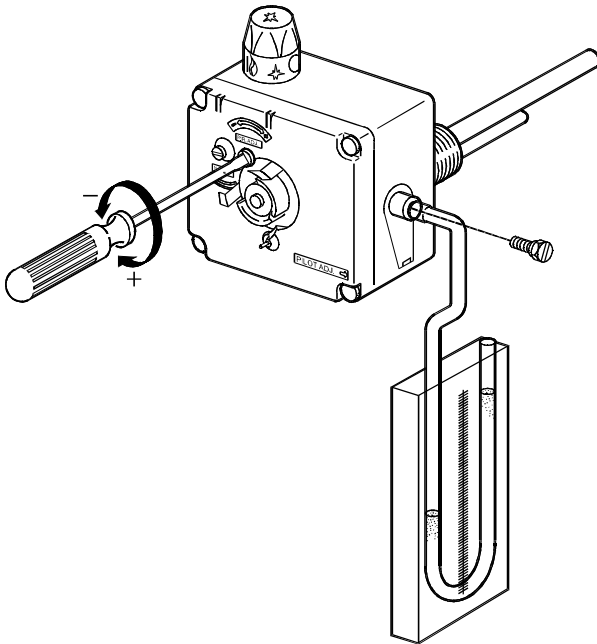

AOS 0486

Drawing 8 - Setting the nominal load

	unit	BCT 75-75			BCT 100-95		
		G20	G30	G31	G20	G30	G31
Inlet pressure	mbar	20	30	37	20	30	37
Burner pressure	mbar	11.5	30	37	10.0	30	37
Diameter main injector	mm	3.90	2.20	2.20	4.50	2.50	2.50
Diameter pilot injector	mm	2x0.27	2x0.16	2x0.16	2x0.27	2x0.16	2x0.16

Procedure:

1. Close the main gas tap in the gas supply;
  2. Demount the burner (see "Cleaning");
  3. Replace the injector of the main burner and the pilot burner with the correct injectors from the conversion set (see table above);
- 4a. Conversion from natural gas to LP-gas:
- Put the pressure regulation of the

gas control block out of operation. To do this the temperature regulating knob should be pulled straight forward. Next the red plastic cover that is now visible, should be removed. Turn the 'no pr' (no pressure regulation) screw down tight (see drawing 9)

- Remount the burner in reverse order.
- Open the main gas tap.

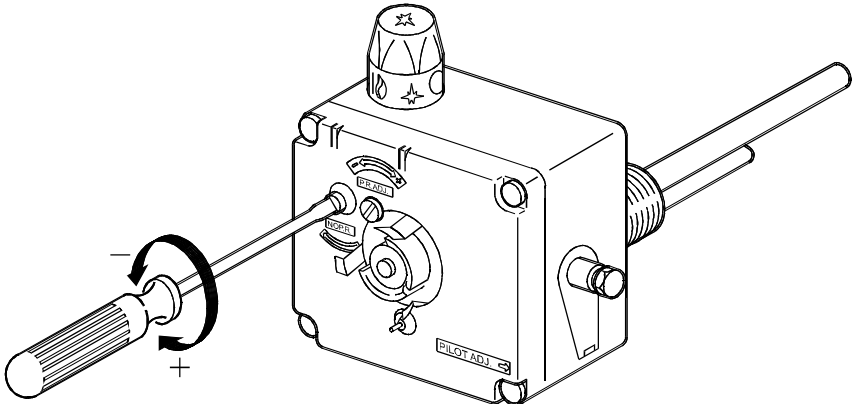

AOS 0487

Drawing 9 - Conversion to another gas

4b. Conversion from LP-gas to natural gas:

- Put the pressure regulator into operation. To do this the temperature regulating knob should be pulled straight forward. Next the red plastic cover that is now visible, should be removed. Turn the 'no pr' (no pressure regulation) screw completely up (see drawing 9).
- Remount the burner in reverse order.
- Open the main gas tap.
- Set the correct burner pressure (see table above).

5. If necessary adjust the pilot correctly (see "Pilot adjustment").

6. Fit the correct sticker from the conversion set on the appliance so that it is clear that the appliance has been converted and on which gas the appliance operates.

If it is necessary to replace the anode it should always be replaced by one of the same type.

The type of anode required can be determined on the basis of the type of the appliance and the serial number.

## 2.8 Maintenance

To ensure safe and efficient operation of the water heater it is recommended that it is cleaned and serviced at least once a year by a qualified competent person.

### 2.8.1 Sacrificial anode

The life cycle of the anode is determined by the quality and the quantity of the water flowing through the apparatus. It is therefore recommended that the anode be inspected and replaced if necessary at least once a year.

1. Close the stop cock in the cold water supply pipe;
2. Open the nearest hot water tap in order to allow the pressure to drop from the water heater and the pipes;
3. Slacken the anode with a fitting wrench;
4. Check the anode and replace it if it has been reduced in diameter by 60% or more at any point on its length;
5. Check for water leaks.

### 2.8.2 Cleaning

1. Close the gas supply and demount the burner after it has cooled down.
2. Disconnect the burner, pilot pipe and thermo couple from the gas control block (see drawing 10).
3. Remove the complete burner assembly.
4. Clean the burner with a soft brush.
5. Check the pilot burner and clean it if so required.
6. Check the combustion chamber, flue tube and flue baffle and clean these if required.
7. Re-mount in reverse order. Tighten the thermo couple connection on the gas control block hand tight and tighten it further with a wrench to a maximum of 1/4 turn as it only needs to make contact.

After cleaning of the pilot- and main burner the operation of these should be checked. If necessary the burner pressure of the main burner should be reset.

### 2.8.3 Decalcification

Formation of lime scale depends on the quality and quantity of the water used. In addition higher water temperatures lead to more deposit in the appliance. A temperature setting of 60°C is recommended in order to keep the calcification at a low level. Decalcification should be attempted with the proper means. For extensive information a decalcification instruction is available.

### 2.8.4 Spare parts

To be able to order spare parts it is important to note the type of appliance as well as the serial number of the appliance. Based on this information the data concerning the spare parts can be determined.

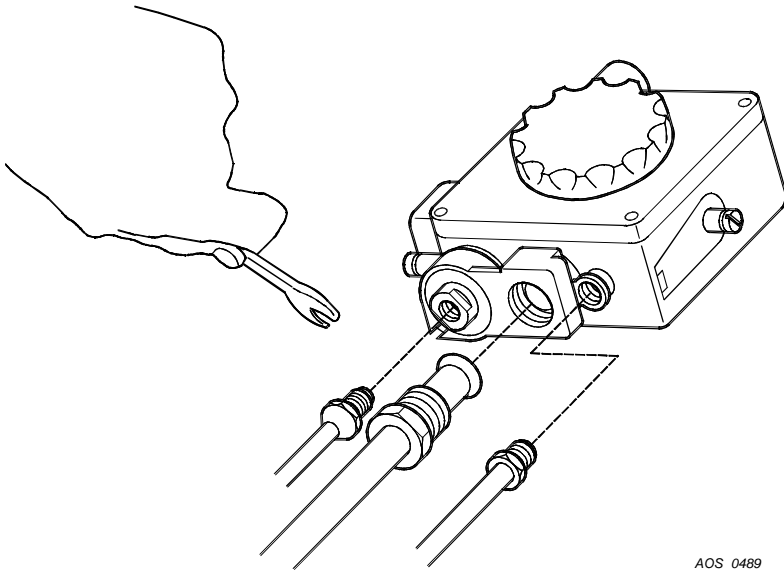

AOS 0489

Drawing 10 - Mounting burner-set

## 2.9 Inlet combination

Not applicable in U.K. and Ireland.

## 2.10 Fault finding

In case of failure the following should be checked.

### 2.10.1 Safety thermostat

All appliances have been fitted with a safety thermostat that shuts off the gas supply when the water temperature is too high. The safety thermostat remains activated until the water temperature drops below the safety temperature. The water heater must be reignited manually. The regulation thermostat should be set to a lower water temperature. If the pilot is extinguished repeatedly at higher temperatures than normal, this indicates that the safety thermostat is operating.

### 2.10.2 Flue down draught safety device

If the flue tube safety device has switched off the appliance, the appliance can be put back into operation through the normal procedure. If the flue tube safety device repeatedly puts the appliance out of operation then this points to problems with the flue. The only remedy is to determine the cause of the problem (for instance a blocked chimney) and to solve the problem.

### 2.10.3 Hot water temperature too low

1. Check the setting of the temperature control knob;
2. Check whether the pilot is alight. If necessary ignite (see "Putting into operation");
3. Check whether there are any leaks or open taps;
4. Is the gas supply adequate? Check and correct if necessary;
5. Perhaps the hot water consumption is higher than was originally calculated;
6. Check whether the cold water inlet

- has been correctly connected;
7. Check the thermostat sensor for scale build up.

### 2.10.4 Hot water temperature too high

Check whether the control thermostat is set too high.

#### Possible water leakage

1. Check whether the drain tap is fully closed;
2. Check whether all water connections are water tight;
3. Check whether the possible water leakage could be caused by condensation.

## 2.11 Gas smell

### Warning

Immediately shut the main gas tap. Do not light any fire or switch on any lights, do not use any electrical switches or alarm bells. Open windows. Thoroughly inspect all gas connections and, if the gas smell persists, alert the local gas company and/or your installer.

## 2.12 Condensation

If the appliance is filled with cold water or if the hot water consumption is very high, condensation of flue gasses will occur on the cold surfaces of the combustion chamber and the flue tube. The water drops will fall on the burner and cause a sizzling noise. This is a normal phenomenon that will disappear as soon as the appliance reaches its normal operating temperature.

### IMPORTANT WARNING

**The appliance should NEVER be taken into operation with a closed cold water supply!  
Provision should always be made for expansion.**

## 3. FOR THE USER

### 3.1 Commissioning

#### **Warning**

Installing and commissioning (for the first time) of this water heater should only be carried out by a qualified competent heating engineer.

#### 3.1.1 Filling the water heater

1. Close the drain tap;
2. Open the cold water tap to the water heater and open all taps where hot water can be drained for de-aeration. The water heater is filled as soon as cold water flows from all taps;
3. Close all hot water drain taps.

#### 3.1.2 Putting into operation

1. Check whether the device has been filled with water and whether the gas supply to the water heater is open;
2. Turn the temperature control knob clockwise and place the control knob in the 'PILOT'-position (✱);
3. Remove the outer door of the combustion chamber;
4. Keep the control button pushed-in and press the piezo-ignitor several times until the pilot burns (see drawing 6);
5. Keep the control button (✱) pushed-in for approximately 20 seconds. After releasing the button the pilot should remain burning. If the pilot extinguishes you should wait 5 minutes before repeating the ignition procedure;
6. Fit the outer door;
7. Turn the control button to the 'ON' (♣) position;
8. Place the temperature control button in the correct position, preferably position 3 (approximately 60°C). The appliance will now operate fully automatically.

#### 3.1.3 Use

The appliance is under water

supply pressure (with a maximum of 8 bar). The amount of cold water that is added is equal to the amount of hot water used. The gas control block automatically regulates the gas supply. The main burner will ignite as soon as a reduction in water temperature is sensed by the control thermostat. The main burner will shut down as soon as the water temperature returns to the preset temperature.

Position 1 = approximately 40°C  
Position 2 = approximately 50°C  
Position 3 = approximately 60°C  
Position 4 = approximately 70°C  
Position 5 = approximately 80°C

Higher water temperatures will cause more scale build up in the appliance. It is for this reason that it is recommended to place the temperature control knob in position 3 as the accumulation of scale will be reduced at lower temperatures. In addition a safety thermostat has been fitted. This thermostat completely shuts off the gas supply if the water temperature reaches 90°C, also extinguishing the pilot burner.

#### 3.1.4 Putting out of operation

1. For short periods of time the control knob should be turned to (✱); the pilot keeps burning;
2. For longer periods of time the knob should be turned to the (●) position; the pilot is extinguished;
3. Close the gas tap in the supply pipe. In case of longer interruptions or in the event of risk of frost it is recommended to also close the cold water tap and to drain the appliance after cooling (open the drain tap; it is possible to connect a drain hose to the drain tap; open the nearest hot water drain point to prevent airlocks).  
To be able to drain the appliance completely it should be disconnected and tilted slightly in the direction of the drain tap.

### **3.1.5 Maintenance**

The inlet combination has to be tested regularly by relieving it (via the relief button). The water has to flow out in a forceful jet. Check whether the discharge pipe is open.

We recommend a service agreement on an annual basis.

To be able to order spare parts it is important to note the type of appliance as well as the serial number of the appliance. Based on this information the data concerning the spare parts can be determined.

### 3.2 Fault finding

Failure	Possible Cause	Corrective Action
Gas smell		If you smell gas you should immediately close the main gas tap you should not light any fire or switch on light, electrical switches or bells. Open windows and immediately contact your installer or the local gas company.
Pilot extinguishes	Blocked pilot burner	Clean the pilot burner
	Blocked chimney	Find the cause and remove it.
	Safety thermostat	Set the temperature regulator at a lower temperature.
	Thermocouple defective	Replace the thermocouple
	Thermocouple makes no contact	Restore the connection
	Gas supply closed	Open the gas tap
Insufficient hot water, or none at all	Temperature is set too low	Set the temperature regulator at a higher temperature
	Control knob in position (★) (pilot burns)	Turn the temperature regulator completely clockwise; turn control button to "on" (Ⓢ); turn the temperature regulator to the desired position, preferably position 4. The appliance now operates fully automatically.
	Control knob in position (●)	Put the appliance into operation.
	Flue safety device closed the gas supply	Press the reset button - if present - on the safety thermostat and put the appliance into operation. If this occurs more often then you should inform your installer.
	Gas supply closed	Open the gas tap and put the appliance into operation.
	Safety thermostat has closed the gas supply because the water temperature was too high	Set the temperature regulator at a lower temperature and reignite the pilot burner.
	Hot water storage empty	Reduce the consumption of hot water. Allow the appliance time to heat the water.
	Cause cannot be determined	Turn the control button to the (●) position. Close the gas tap and inform your installer.
Water leakage	Condensation of (flue) gasses	See "Condensation".
	Insufficient sealing of the water connections (thread)	Tighten the threaded connections.
	Leakage from other water- appliances or pipes near by	Trace the cause.

## 4. WARRANTY

The following conditions form the guarantee agreement between BSS GROUP PLC (the warrantor) and the owner of the water heater.

### 4.1 Warranty in general

If within one year of the original installation date of the water heater any part or component other than the tank shall prove upon examination by the warrantor or authorised agent to be defective in material or workmanship, the warrantor will exchange such part or component.

### 4.2 Warranty of the tank

If within 3 years of the original installation date, the tank fails due to rust or corrosion from the water side, the warrantor will supply a complete new water heater of equivalent size and duty (excluding delivery and installation charges). On the replacement water heater a guarantee will be granted sufficient to cover the unexpired portion of the original 3 year guarantee of the originally installed water heater.

### 4.3 Conditions for installation and use

The guarantee applies to the heater only while it remains in its original location, and is installed in accordance with local plumbing and building regulations and all relevant Codes of Practice.

The water heater should also have been used only:

- a) for potable water free to circulate at all times and with the tank free of damaging scale deposits;
- b) at temperatures not exceeding the maximum setting of its thermostat and ECO (Energy Cut Off device);
- c) at water pressures and/or energy inputs which do not exceed those stated on the rating plate of the water heater;

- d) in a non corrosive atmosphere or area;
- e) with an approved temperature and pressure relief valve of adequate capacity not exceeding the working pressure rating shown on the water heater, and installed in conformity with BSS GROUP PLC installation instructions;
- f) when anode(s) have been inspected and renewed, if they are worn or eroded by 50% of more at any point of their length.

### 4.4 Exclusions

The guarantee will be null and void:

- a) if the water heater has been damaged by an external cause;
- b) in case of misuse, neglect (including frost damage) or incorrect use of the water heater;
- c) in case of unauthorised alteration, modification or repair;
- d) in case of ingress into the water heater of chemicals, pollutants or contaminants;
- e) if the hardness of the incoming water is, or has been, softened below 106 ppm  $\text{CaCO}_3$ ;
- f) if the water heater is effected by corrosive vapours such as those found in hairdressers, dry cleaners and laundries or where some industrial degreasing products are used and stored (for further information and advice please contact the BSS GROUP PLC Technical Department).

### 4.5 Range of guarantee

All replacement water heaters supplied under the terms of this warranty will be supplied ex stock on an F.O.B. basis. BSS GROUP PLC accepts no responsibility for carriage, labour or other installation costs.

#### **4.6 Claims**

Any claim under this warranty should be initiated with the dealer who originally sold the water heater or with any other dealer or stockist of the warrantors products.

#### **4.7 No other guarantee or warranty either expressed or implied is made on behalf of BSS GROUP PLC .**

With respect to the water heater in question further BSS GROUP PLC does not guarantee this water heater as suitable for purpose except within the terms of warranty detailed above.

BSS GROUP PLC will not be liable by virtue of this guarantee or otherwise for damage to any persons or property when arising out of contracts or tort.

The terms of this guarantee do not effect your statutory rights under United Kingdom Consumer Legislation.

This guarantee applies to the model BCT 75-75 G and BCT 100-95 G





