

Instructions for the Installation and Maintenance of AD1.0M/T EUROINOX

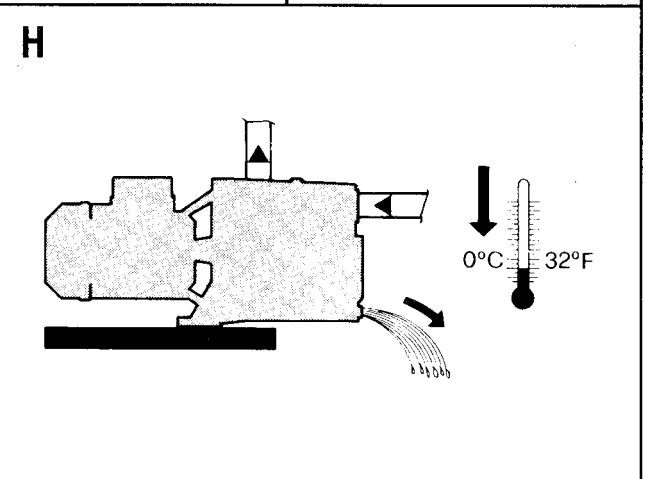

Pipeline & Heating Solutions

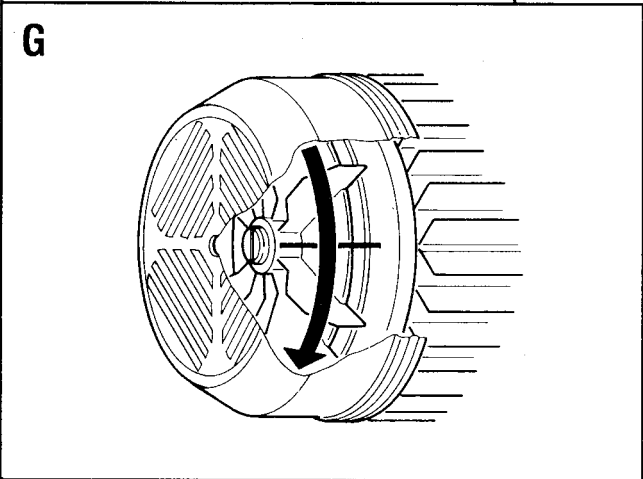

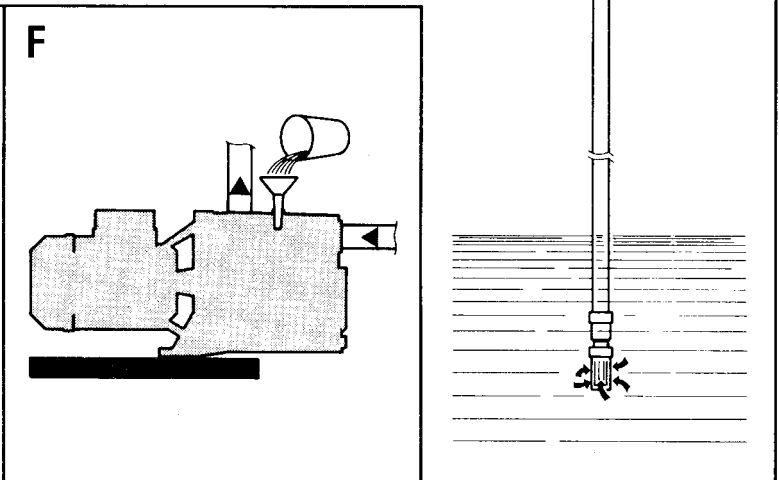
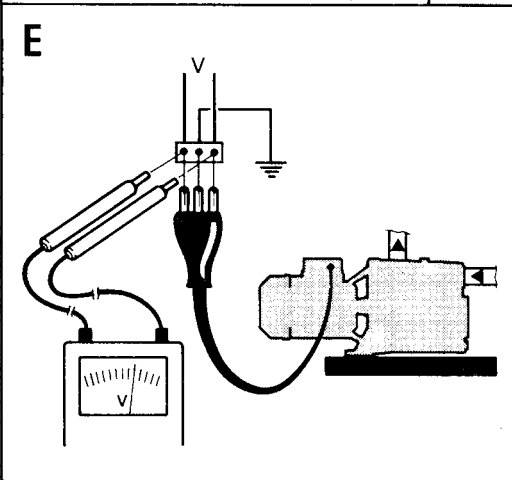
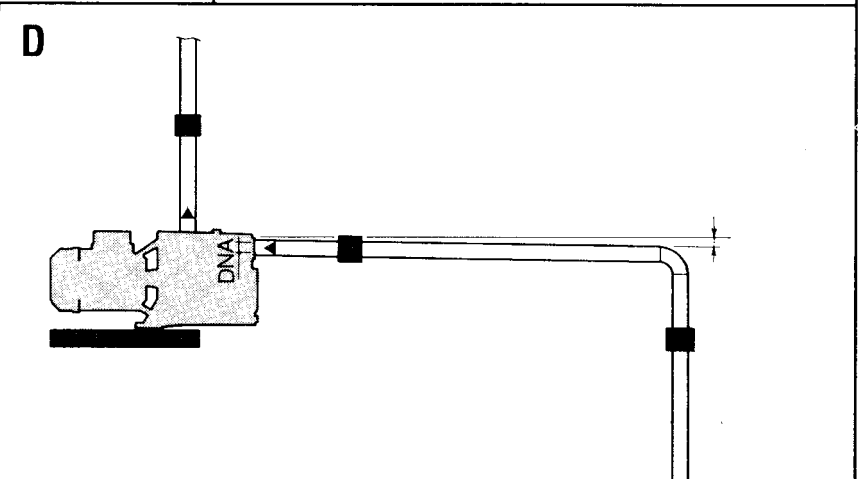
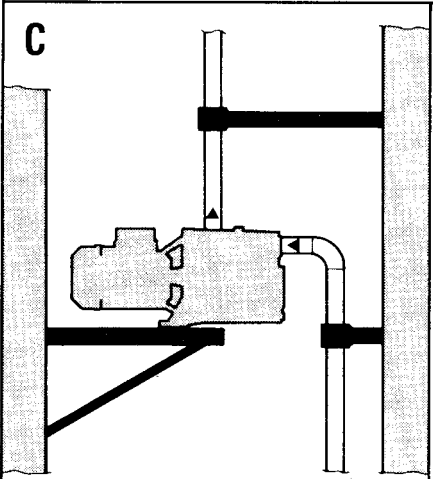
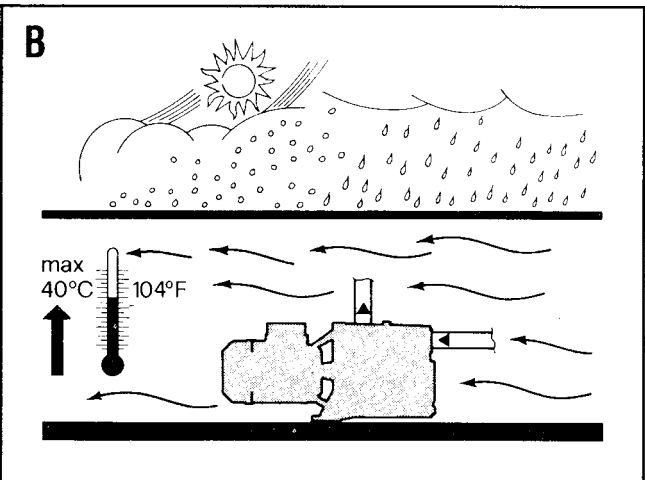
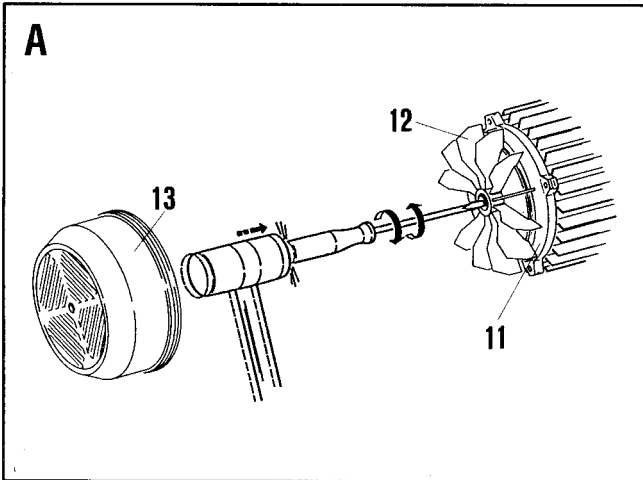



Pipeline & Heating Solutions

EUROINOX 25/30 - EUROINOX 30/30 - EUROINOX 40/30
EUROINOX 25/306 - EUROINOX 30/306 - EUROINOX 40/306

EUROINOX 25/80 - EUROINOX 30/80 - EUROINOX 40/80
EUROINOX 25/806 - EUROINOX 30/806 - EUROINOX 40/806

DICHIARAZIONE DI CONFORMITÀ

La Ditta DAB PUMPS s.p.a. - Via M. Polo,14 - Mestrino (PD) - ITALY - sotto la propria esclusiva responsabilità dichiara che i prodotti summenzionati sono conformi a:

- Direttiva del Consiglio n° 98/37/CE concernente il riavvicinamento delle legislazioni degli Stati membri CEE relative alle macchine e successive modifiche.
- Direttiva della Compatibilità elettromagnetica 89/336 e successive modifiche.
- Direttiva Bassa Tensione 73/23 e successive modifiche.
- Direttiva 2000/14/CE relativa all'emissione acustica.

DECLARATION OF CONFORMITY

The Company DAB PUMPS s.p.a. - Via M. Polo,14 - Mestrino (PD) - ITALY - declares under its own responsibility that the above-mentioned products comply with:

- Council Directive no. 98/37/CE concerning the reconciliation of the legislations of EEC Member Countries with relation to machines and subsequent modifications.
- Directive on electromagnetic compatibility no. 89/336 and subsequent modifications.
- Directive on low voltage no. 73/23 and subsequent modifications.
- Directive 2000/14/CE on noise emission.

CONFORMITEITSVERKLARING

De firma DAB PUMPS s.p.a. - Via M. Polo, 14 Mestrino (PD) - Italië, verklaart hierbij onder haar verantwoording dat hierbovengenoemde producten conform zijn aan:

- de Richtlijn van de Raad nr. 98/37/CE betreffende harmonisatie van de wetgeving in de EEG-lidstaten t.a.v. machines en daaropvolgende wijzigingen.
- De richtlijnen van de elektromagnetische overeenstemming 89/336 en latere veranderingen.
- De richtlijnen voor lage druk 73/23 en latere veranderingen.
- Richtlijn 2000/14/EG met betrekking tot geluidsemissie.

FÖRSÄKRAN OM ÖVERENSSTÄMMELSE

Bolaget DAB PUMPS s.p.a. - Via M. Polo,14 - Mestrino (PD) - ITALIEN - intygar på eget ansvar att ovanstående produkter är i enlighet med:

- Rådets direktiv nr. 98/37/CE och efterföljande ändringar som innehåller en jämkning av EU-ländernas lagstiftning beträffande maskiner.
- EMC-direktivet nr. 89/336 och efterföljande ändringar.
- Lågspänningsdirektiv nr. 73/23 och efterföljande ändringar.
- EU-direktiv 2000/14/EG om buller i miljön.

DÈCLARATION DE CONFORMITÈ

L'entreprise DAB PUMPS s.p.a. - Via M. Polo,14 - Mestrino (PD) - ITALIE - déclare sous sa responsabilité exclusive que les produits susmentionnés sont conformes à:

- la Directive du Conseil n° 98/37/CE concernant l'harmonisation des législations des Etats membres de la CEE relatives aux machines et ses modifications successives.
- la Directive de la compatibilité électromagnétique 89/336 et ses modifications successives.
- la Directive basse tension 73/23 et ses modifications successives.
- Directive 2000/14/CE relative aux émissions sonores.

KONFORMITÄTSERKLÄRUNG

Die Firma DAB PUMPS s.p.a. - Via M. Polo,14 - Mestrino (PD) - ITALY - erklärt unter ihrer eigenen, ausschließlichen Verantwortung, daß die genannten Produkte den folgenden Verordnungen entsprechen:

- Ratsverordnung Nr. 98/37/CE über die Angleichung der Gesetzgebung der CEE-Staaten über Maschinen und folgende Abänderungen.
- Verordnung über die elektromagnetische Kompatibilität 89/336 und folgende Abänderungen.
- Verordnung über Schwachstrom 73/23 und folgende Abänderungen.
- Richtlinie 2000/14/EG zur Geräuschemission.

DECLARACION DE CONFORMIDAD

La Empresa DAB PUMPS s.p.a. - Via M. Polo,14 - Mestrino (PD) - ITALY - bajo su propia y exclusiva responsabilidad declara que los productos anteriormente mencionados respetan:

- Las Directrices del Consejo n° 98/37/CE referentes a la homogeneización de las legislaciones de los Estados miembros de la CEE relativas a las máquinas y sucesivas modificaciones.
- Directriz de la Compatibilidad electromagnética 89/336 y sucesivas modificaciones.
- Directriz Baja Tensión 73/23 y sucesivas modificaciones.
- Directiva 2000/14/CE relativa a la emisión acústica.

UYGUNLUK BEYANI

Via M. Polo, 14 – Mestrino (PD) –İTALYA’da bulunan DAB PUMPS S.p.A., kendi sorumluluğunu üstüne alarak yukarıda belirtilen ürünlerin:

- AET üyelerinin makinelerle ilgili normlar ile ilişkin tamamlamalarının uyumlaştırılmasına, 98/37/CE sayılı Avrupa Konseyi Yönetmeliğine.
 - 89/336 sayılı AET Elektromanyetik Uyum Yönetmeliği ile ilişkin tamamlamalarına.
 - 73/23 sayılı AET Alçak Gerilim Yönetmeliği ile ilişkin tamamlamalarına uygun olduklarını beyan eder.
 - Ses seviyesine ilişkin 2000/14/CE Yönetmeliği.
-

ЗАЯВЛЕНИЕ О СООТВЕТСТВИИ

Фирма DAB PUMPS s.p.a. – Via Marco Polo, 14 Mestrino (PD) ИТАЛИЯ- под собственную исключительную ответственность заявляет, что вышеуказанные агрегаты соответствуют:

- Директиве Совета н° 98/37/CE касательно сближения законодательств Государств членов ЕЭС в области агрегатов и последующим поправкам.
- Директиве об Электромагнитной совместимости 89/336 и последующим поправкам.
- Директиве о низком напряжении 73/23 и последующим поправкам.
- Директива 2000/14/CE по акустическому излучению.

DECLARATIE DE CONFORMITATE

Firma DAB PUMPS s.p.a. – Via M. Polo, 14 – Mestrino (PD) – Italia – declara pe propria raspundere ca produsele mentionate mai sus in conformitate cu:

- Directiva Consiliului nr. 98/37/CE privind armonizarea legislatiilor Statelor membre CEE referitoare la masini cu modificarile sale ulterioare.
- Directiva referitoare la compatibilitatea electromagnetica 89/336 si modificarile ulterioare.
- Directiva referitoare la Joasa Tensiune 73/23 si modificarile ulterioare.
- Directiva 2000/14/CE referitoare la emisia acustica.

شهادة مطابقة

DAB PUMPS S.p.A. الشركة
VIA M. POLO 14
MESTRINO (PD)
ITALY

- تحت مسؤوليتها الخاصة تشهد بأن المنتجات المذكورة أعلاه صنعت مطابقة إلى:
- قانون مجلس الوزراء المؤرخ رقم 98/37/CE وما لحقه من تغييرات.
 - القانون الخاص بالمطابقة الإلكترونية ومغناطيسية 89/336 وما لحقه من تغييرات.
 - القانون الخاص بالجهد المنخفض 73/23 وما لحقه من تغييرات.
 - قانون 2000/14/CE الذي يخص الإنبعاث الصوتي

ATITIKTIES DEKLARACIJA

DAB PUMPS s.p.a. – Via M. Polo, 14 – Mestrino (PD) – Italija – garantuoja, kad šiame leidinyje išvardyti gaminiai atitinka:

- Tarybos direktyvą Nr. 98/37/CE, bei jos pataisas suderintas su ES valstybių įstatymais, susijusiais su mechanizmais.
- Elektromagnetinio suderinamumo direktyvą Nr. 89/336, bei jos pataisas.
- Įrenginių skirtų naudoti tam tikros įtampos ribose direktyvą Nr. 73/23, bei jos pataisas.

DECLARAÇÃO DE CONFORMIDADE

A Firma DAB PUMPS s.p.a. - Via M. Polo, 14 - Mestrino (PD) - ITÁLIA – sob sua exclusiva responsabilidade declara que os produtos atrás citados estão em conformidade com:

- Directiva do Conselho n° 98/37/CE relativa à aproximação das legislações dos Estados-Membros CEE respeitantes às máquinas e sucessivas alterações.
- Directiva da Compatibilidade electromagnética 89/336 e sucessivas alterações.
- Directiva Baixa Tensão 73/23 e sucessivas alterações.
- Directiva 2000/14/CE relativa à emissão acústica.

确认声明

DAB PUMPS s.p.a公司，位于意大利Via M. Polo, 14 – Mestrino (PD), 声明其责任下的以上产品符合如下标准:

- 符合欧洲经济共同体成员国法规的修正中有关机械产品部分及随后所做的修改，98/37/CE号议会指令文件。
- 符合电磁兼容89/336号指令及其修正文件。
- 符合低电压73/23号指令及其修正文件。
- 符合噪音传播2000/14/CE号指令。

Mestrino (PD), 07 Gennaio 2003

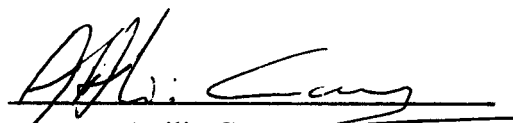

Attilio Conca
Legale Rappresentante
Legal Representative

	page
1. CONTENTS	
1. GENERAL	13
2. APPLICATIONS	13
3. PUMPED FLUIDS	13
4. TECHNICAL DATA AND RANGE OF USE	13
5. MANAGEMENT	15
5.1. Storage	15
5.2. Transport	15
5.3. Weights	15
6. WARNINGS	15
6.1. Skilled personnel	15
6.2. Safety	15
6.3. Checking motor shaft rotation	15
6.4. Responsibility	15
7. INSTALLATION	15
8. ELECTRICAL CONNECTION	16
9. STARTING UP	16
10. PRECAUTIONS	16
11. MAINTENANCE AND CLEANING	16
12. MODIFICATIONS AND SPARE PARTS	17
12.1. Removal and replacement of the supply cable	17
13. TROUBLESHOOTING	18

1. GENERAL



Read this documentation carefully before installation. Installation and functioning must comply with the safety regulations in force in the country in which the product is installed. The entire operation must be carried out in a workmanlike manner.

Failure to comply with the safety regulations not only causes risk to personal safety and damage to the equipment, but invalidates every right to assistance under guarantee.

2. APPLICATIONS

KP 38/18 - KP 38/18 pred. - KP 60/6 - KP 60/12: Peripheral pump suitable for domestic use, with limited bulk, capable of generating high heads for water supply, small gardening jobs, draining and filling cisterns. Also suitable for small industrial uses.

KPA 40/20: liquid ring pump with star-shaped impeller, with excellent suction capacities even in the presence of air bubbles or when the fluid to be lifted is not continuously available. Used particularly for supplying water to household systems, for increasing pressure or stabilising the water supply (in compliance with local regulations) and for lifting water from wells. Suitable for small irrigation work in gardens and in general for all applications where a self-priming pump is required. It can also satisfy small industrial applications.

JET 200 - JET 300 - JET 151 - JET 251: Self-priming centrifugal jet pumps with excellent suction capacity, even when gas is present in the water. Particularly suitable for water supply uses and for pressurization in the home. Suitable for small farming applications, market gardens, gardening, emergencies in the home and industrial utilities.

DP 81 - DP 100 - DP 151 - DP 251: Self-priming centrifugal pumps for suction at depths of as many as 30 metres with ejector to be fitted in 4" wells or larger. Used for supplying water to farm houses and in small farming applications.

EURO - EUROINOX and derived models: Self-priming multistage centrifugal pump with horizontal action, suitable for domestic or industrial uses, for water supply systems and pressurization. In farming it is ideal for small irrigation work and for washing tools and machinery. Also suitable for water containing gas. Water is recycled only during the priming stage, after which the maximum flow is made available for use with continuous and constant distribution. These qualities allow vast possibilities for use.

K 20/41 - K 30/70 - K 30/100 - K 36/100 - K 12/200 - K 14/400: Single-impeller centrifugal pumps suitable for lifting water for domestic, industrial and agricultural use. Excellent for transfer and mixing operations.

K 35/40 - K 45/50 - K 55/50 - K 35/100 - K 40/100: Centrifugal pumps characterized by the use of two impellers (opposed for models K 35/40 - K 45/50 - K 55/50), with extremely silent operation. Particularly suitable for use in pressurization units for water supply systems and for feeding autoclaves. Also suitable for sprinkling irrigation and many other uses in the most varied fields of application.

3. PUMPED FLUIDS



The machine has been designed and built for pumping water, free from explosive substances and solid particles or fibres, with a density of 1000 kg/m³ and a kinematic viscosity of 1 mm²/s, and chemically non-aggressive liquids.

4. TECHNICAL DATA AND RANGE OF USE

– Supply voltage:	220 - 240V 50Hz	see electrical data plate
	110V 50Hz	
	115V 60Hz	
	230V 60Hz	
	230 V3 – 400 V3 50/60Hz	

- **Absorbed power:** see electrical data plate
- **Delivery:** from 0,06 to 37 m³/h
- **Head up – Hmax (m):** pag. 83
- **Pumped liquid:** clean, free from solid bodies or abrasive substances, non-aggressive.
- **Degree of motor protection:** IP44 (For IP55 see plate on package)
- **Degree of terminal board protection:** IP55
- **Protection class:** F
- **Cable clamp:** PG 11 and/or PG 13.5, depending on models

- **Line fuses AM class:**

Model	Line fuses(Amps)			
	110V 50Hz 115V 60Hz	220-240V 50Hz 230V 60Hz	230 V3 50/60Hz	400 V3 50/60Hz
KP 38/18, KP 38/18 Pred., KP 60/6, DP 81, K 20/41	8	4	4	2
KPA 40/20	8	6	4	2
KP 60/12;	--	6	4	4
EURO 40/30-40/306 / 30/50-30/506 / 25/80-25/806 EUROINOX 40/30-40/306 / 30/50-30/506 / 25/80-25/806 EUROCOM 25/80-25/806 / 30/50-30/506 EUROCOM SP 30/50-30/506	10	6	4	4
EURO 25/30-25/306 / 30/30-30/306 EUROINOX 25/30-25/306 / 30/30-30/306 EUROCOM 25/30-25/306 / 30/30-30/306 GARDEN-INOX 30/30	8	4	4	4
EURO 40/50-40/506 / 30/80-30/806 EUROINOX 40/50-40/506 / 30/80-30/806 EUROCOM 40/50-40/506 / 30/80-30/806 EUROCOM SP 40/50-40/506 GARDEN-INOX 40/50	12	6	6	4
EURO 50/50-50/506 / 40/80-40/806 EUROINOX 50/50-50/506 / 40/80-40/806	20	8	6	4
K 12/200, K 30/70, K 35/40, DP 100	12	6	6	4
K 30/100	16	8	6	4
JET 151, K 35/100	20	10	6	4
K 40/100, K 36/100, K45/50, DP 151	20	10	8	4
JET 200, K 14/400	20	10	8	6
JET 251	25	12	8	6
JET 300, K 55/50, DP 251	32	16	10	6
Maximun operating pressure:	6 bar (600 kPa):	DP 81, DP 100 EURO, EUROINOX, EUROCOM, EUROCOM SP, GARDEN-INOX K 35/40, K 35/100, K 40/100, K 20/41, K 30/70, K 30/100, K 36/100, K 12/200, K 14/400		
	7,5 bar (750 kPa):	JET 151, JET 251, JET 200, JET 300 DP 151, DP 251		
	8 bar (800 kPa):	K 45/50, K 55/50		
	10 bar (1000 kPa):	KP 60/6, KP 60/12, KP 38/18 KPA 40/20		
Liquid temperature range:	0 ÷ +35°C:	For all homologated pumps EN 60335-2-41 (for domestic uses)		
	0 ÷ +40°C:	JET 151, JET 251, JET 200, JET 300 DP 81, DP 100, DP 151, DP 251		
	-10 ÷ +50°C:	K 20/41, K 30/70, K 30/100, K 36/100, K 12/200, K 35/40, K 45/50, K 35/100, K 40/100 KP 38/18		
	-10 ÷ +80°C:	KP 60/6, KP 60/12 KPA 40/20		
	-15 ÷ +110°C:	K 14/400, K 55/50		

- **Storage temperature:** -10°C to +40°C
- **Relative humidity of the air:** MAX. 95%
- **Noise level:**
 - For pumps intended for outdoor use: noise emission according to Directive 2000/14/CE.
 - For other pumps: noise emission according to Directive EC 89/392/CEE and subsequent amendments.
- Motor construction in conformity with standards CEI 2-3 - CEI 61-69 (EN 60335-2-41)

5. MANAGEMENT

5.1 Storage

All the pumps must be stored indoors, in a dry, vibration-free and dust-free environment, possibly with constant air humidity.

They are supplied in their original packaging and must remain there until the time of installation. If this is not possible, the intake and delivery aperture must be accurately closed.

5.2 Transport

Avoid subjecting the products to needless jolts or collisions.

To lift and transport the unit, use lifting equipment and the pallet supplied standard (if applicable).

5.3 Weights

The adhesive label on the package indicates the total weight of the electropump.

6. WARNINGS

6.1 Skilled technical personnel



It is advisable that installation be carried out by skilled personnel in possession of the technical qualifications required by the specific legislation in force.

The term **skilled personnel** means persons whose training, experience and instruction, as well as their knowledge of the respective standards and requirements for accident prevention and working conditions, have been approved by the person in charge of plant safety, authorizing them to perform all the necessary activities, during which they are able to recognize and avoid all dangers. (Definition for technical personnel IEC 364).

6.2 Safety

Use is allowed only if the electric system is in possession of safety precautions in accordance with the regulations in force in the country where the product is installed (for Italy, CEI 64/2).

6.3 Checking motor shaft rotation

Before installing the pump you must check that the rotating parts turn freely. For this purpose remove the fan cover from its seat in the motor end cover. Insert a screwdriver in the notch on the motor shaft from the ventilation side. If there is a blockage, turn the screwdriver, tapping it gently with a hammer. **FIG. A**

6.4 Responsibility



The Manufacturer does not vouch for correct operation of the pumps if they are tampered with or modified, run outside the recommended work range or in contrast with the other instructions given in this manual.

The Manufacturer declines all responsibility for possible errors in this instructions manual, if due to misprints or errors in copying. The company reserves the right to make any modifications to products that it may consider necessary or useful, without affecting the essential characteristics.

7. INSTALLATION

- 7.1 The electropump must be fitted in a well ventilated place, protected from unfavourable weather conditions and with an environment temperature not exceeding 40°C. Fig.B
- 7.2 A firm anchoring of the pump to the bearing surface favours the absorption of any vibrations caused by pump operation. **Fig. C**
- 7.3 Ensure that the metal pipes do not exert undue strain on the apertures, thus preventing deformations or breakages. **Fig. C**
- 7.4 **It is always good practice to place the pump as close as possible to the liquid to be pumped.** The pump must be installed only in horizontal position. The internal diameters of the pipes must never be smaller than that of the mouth of the electropump. It is advisable to fit a foot valve on suction. **Fig. D** For suction depths of over four metres or with long horizontal stretches it is advisable to use an intake hose with a diameter larger than that of the intake aperture of the pump. To prevent the formation of air pockets, the intake hose must slope slightly upwards towards the pump. **Fig. D**

- 7.5 If the intake pipe is made of rubber or flexible material, always check that it is of the reinforced type to avoid throttling due to suction.
- 7.6 The lifting and carrying handle **must always be present and well fixed to the support** on all pumps produced in the portable version.
- 7.7 **Pumps that are to be used in fountains for outdoor use, in garden ponds and similar places, must be fed by means of a circuit equipped with a differential current device, the rated operating differential current of which is not higher than 30 mA.**

8. ELECTRICAL CONNECTION

Caution! always follow the safety regulations.



Scrupulously follow the wiring diagrams inside the terminal board box.

- 8.1 **Electric installation must be carried out by skilled and authorized electrician who accepts all the responsibility for the job.**
- 8.2 Ensure that the mains voltage is the same as the value shown on the motor plate and that there is the possibility of **MAKING A GOOD EARTH CONNECTION. Fig. E**
- 8.3 In fixed installations, International Safety Standards require the use of isolating switches with a fuse-carrier base.
- 8.4 Single-phase motors are provided with built-in thermal overload protection and may be connected directly to the mains. Three-phase motors must be protected with an automatic switch (e.g circuit breaker) calibrated at the values shown on the data plate of the electropump.

9. STARTING UP

9.1



Do not start the pump unless it has been completely filled with fluid.

Before starting up, check that the pump is properly primed; fill it completely with clean water by means of the hole provided after having removed the filler cap on the pump body. This ensures that the mechanical seal is well lubricated and that the pump immediately starts to work regularly. **(Fig. F). Dry operation causes irreparable damage to the mechanical seal.** The filling cap must then be screwed back on carefully.

- 9.2 Switch on the power and check, on the three-phase version, that the motor is turning in the correct direction; this should be in a clockwise direction, looking at the motor from the impeller side. **Fig. G** If it is turning in the wrong direction, invert the connections of any two wires on the terminal board, after having disconnected the pump from the power mains.

10. PRECAUTIONS

- 10.1 The electropump should not be started more than 20 times in one hour so as not to subject the motor to excessive thermal shock.
- 10.2 **DANGER OF FROST:** When the pump remains inactive for a long time at temperatures of less than 0°C, the pump body must be completely emptied through the drain cap **Fig. H**, to prevent possible cracking of the hydraulic components. This operation is advisable even in the event of prolonged inactivity at normal temperature.
- 10.3 When starting after long periods of inactivity, the starting-up operations listed above must be repeated.

11. MAINTENANCE AND CLEANING



In normal operation, the pump does not require any specific maintenance. However, it may be necessary to clean the hydraulic parts when a fall in yield is observed. **The electropump must not be dismantled unless by skilled personnel in possession of the qualifications required by the regulations in force.** In any case, all repairs and maintenance jobs must be carried out only after having disconnected the pump from the power mains.

12. MODIFICATIONS AND SPARE PARTS



Any modification not authorized beforehand relieves the manufacturer of all responsibility. All the spare parts used in repairs must be original ones and the accessories must be approved by the manufacturer so as to be able to guarantee maximum safety of the machines and systems in which they may be fitted.



In the event of damage to the power cable of this appliance, the repair must be carried out by skilled personnel, in order to prevent all risks.

12.1 Removal and replacement of the supply cable

Before starting, ensure that the electropump is not connected to the power network.

A) For versions without a pressure switch

Remove the condenser cover, unscrewing the four screws on it. Unscrew the three terminals L - N - ⊕ and disconnect the brown lead, the blue lead and the yellow-green lead, coming from the supply cable, after having slackened the grommet.

B) For versions with a SQUARE D pressure switch

- **Section of cable with plug from the pressure switch:** unscrew the screw from the cover of the pressure switch using a screwdriver and remove the cover. Remove the yellow-green lead, slackening the earth screw, the blue lead and the brown lead from the respective terminals at the side, slackening the screws on the terminals. Remove the cable blocking terminal, slackening the respective screws, and slip off the cable which is now disconnected.
- **Section of cable from the pressure switch to the terminal board:** unscrew the nut from the cover of the pressure switch using a screwdriver and remove the cover. Remove the yellow-green lead, slackening the earth screw, the blue lead and the brown lead from the respective central terminals, slackening the screws on the terminals. Remove the cable blocking terminal, slackening the respective screws, and slip off the cable which is now disconnected. Remove the condenser cover, unscrewing the four screws on it. Unscrew the three terminals L - N - ⊕ and disconnect the brown lead, the blue lead and the yellow-green lead, coming from the pressure switch, after having slackened the grommet.

C) Version with a TELEMECANIQUE / SQUARE D – TELEMECANIQUE / ITALTECNICA pressure switch:

- **Section of cable with plug from the pressure switch:** unscrew the screw from the cover of the pressure switch using a screwdriver and remove the cover, releasing it from the base of the pressure switch. Slip out the yellow-green lead, unscrewing the earth screw on the left side. Still on the same side, slip the blue lead and the brown lead off their terminals, slackening the screws on the terminals. Slacken the cable clamping nut of the pressure switch on the left side and slip off the cable which is now disconnected.
- **Section of cable from the pressure switch to the terminal board:** unscrew the nut on the cover of the pressure switch using a screwdriver and remove the cover, releasing it from the base of the pressure switch. Slip out the yellow-green lead, unscrewing the earth screw on the right side. Still on the same side, slip the blue lead and the brown lead off their terminals, slackening the screws on the terminals. Slacken the cable clamping nut of the pressure switch on the right side and slip off the cable which is now disconnected. Remove the terminal board cover, unscrewing the four screws on it. Unscrew the three terminals L - N - ⊕ and disconnect the brown lead, the blue lead and the yellow-green lead, coming from the supply pressure switch, after having slackened the grommet.

When replacing the power cable, a cable of the same type must be used (e.g. H05 RN-F or H07 RN-F depending on the installation) and with the same terminals, proceeding as for disassembly in inverse order.

ATTENTION: depending on the installation and if the pumps have no cable, fit supply cables type H05 RN-F for indoor use and type H07 RN-F for outdoor use, complete with plug (standards 61-69). For power cables without a plug, provide a device for cutting off the mains (e.g. magnetothermal device) with separating contacts of at least 3 mm for each pole.

13. TROUBLESHOOTING

FAUL	CHECKS (possible cause)	REMEDY
1. The motor does not start and makes no noise.	A. Check the electric connections. B. Check that the motor is live. C. Check the protection fuses.	C. If they are burnt-out, change them. N.B. If the fault is repeated immediately this means that the motor is short circuiting.
2. The motor does not start but makes noise.	A. Ensure that the mains voltage is the same as the value on the plate. B. Ensure that the connections have been made correctly. C. Check that all the phases are present on the terminal board. (3~) D. Look for possible blockages in the pump or motor. E. Check the condition of the capacitor.	B. Correct any errors. C. If not, restore the missing phase. D. Remove the blockage. E. Replace the capacitor.
3. The motor turns with difficulty.	A. Check the voltage which may be insufficient. B. Check whether any moving parts are scraping against fixed parts.	B. Eliminate the cause of the scraping.
4. The pump does not deliver.	A. The pump has not been primed correctly. B. On three-phase motors, check that the direction of rotation is correct. C. The diameter of the intake pipe is insufficient. D. Blocked foot valve.	B. If necessary, invert the connection of two supply wires C. Replace the pipe with one with a larger diameter. D. Clean the foot valve.
5. The pump does not prime.	A. The intake pipe or the foot valve is taking in air. B. The downward slope of the intake pipe favours the formation of air pockets.	A. Eliminate the phenomenon and prime again. B. Correct the inclination of the intake pipe.
6. The pump supplies insufficient flow.	A. Blocked foot valve. B. The impeller is worn or blocked. C. The diameter of the intake pipe is insufficient. D. On three-phase motors, check that the direction of rotation is correct.	A. Clean the foot valve. B. Remove the obstructions or replace the worn parts. C. Replace the pipe with one with a larger diameter. D. If necessary, invert the connection of two supply wires.
7. The pump vibrates and operates noisily.	A. Check that the pump and the pipes are firmly anchored. B. There is cavitation in the pump, that is the demand for water is higher than it is able to pump. C. The pump is running above its plate characteristics.	A. Fix the loose parts more carefully. B. Reduce the intake height or check for load losses. C. It may be useful to limit the flow at delivery.

Modello / Modèle / Model Modell / Model Modelo / Modell / Model Модель / نموذج	Prevalenza / Hauteur d'élévation / Head up Förderhöhe / Overwicht / Prevalencia Maximal pumphöjd / Manometrik yükseklik Hanop / التفتوق	
	<i>Hmax (m) 2 poles 50 Hz</i>	<i>Hmax (m) 2 poles 60 Hz</i>
JET 200	41	42.3
JET 300	51	52
JET 151	61	62
JET 251	62	62
EURO 25/30 – 25/306	34.4	35.9
EURO 30/30 – 30/306	46	48.2
EURO 40/30 – 40/306	57	58.8
EURO 30/50 – 30/506	42.2	38.8
EURO 40/50 – 40/506	57.7	55
EURO 50/50 – 50/506	72	66.1
EURO 25/80 – 25/806	34	35.8
EURO 30/80 – 30/806	47.3	49.5
EURO 40/80 – 40/806	59	62
EUROINOX 25/30 – 25/306	35	35.9
EUROINOX 30/30 – 30/306	46	49
EUROINOX 40/30 – 40/306	57	58.8
EUROINOX 30/50 – 30/506	42.2	38.8
EUROINOX 40/50 – 40/506	57.7	54
EUROINOX 50/50 – 50/506	72	66
EUROINOX 25/80 – 25/806	34	37
EUROINOX 30/80 – 30/806	47.3	52
EUROINOX 40/80 – 40/806	59	60
EUROCOM 25/30 – 25/306	34.4	36
EUROCOM 30/30 – 30/306	46	48
EUROCOM 30/50 – 30/506	42.2	38.8
EUROCOM 40/50 – 40/506	57.7	54
EUROCOM 25/80 – 25/806	34	35.7
EUROCOM 30/80 – 30/806	47.3	49.2
EUROCOM SP 30/50 – 30/506	42.2	38.8
EUROCOM SP 40/50 – 40/506	57.7	53.8
GARDEN-INOX 30/30	46	
GARDEN-INOX 40/50	57.7	
K 20/41	22	24.1
K 30/70	32.5	33
K 30/100	29.2	30.8
K 36/100	34.9	36.4
K 12/200	18.4	19.2
K 14/400	19	18.5
K 35/40	44	44.4
K 45/50	51	53.5
K 55/50	62	60

Modello / Modèle / Model Modell / Model Modelo / Modell / Model Модель / نموذج	Prevalenza / Hauteur d'élévation / Head up Förderhöhe / Overwicht / Prevalencia Maximal pumphöjd / Manometrik yükseklik Hanop / التفتوق	
	<i>Hmax (m) 2 poles</i> 50 Hz	<i>Hmax (m) 2 poles</i> 60 Hz
K 35/100	38.5	37.5
K 40/100	44	46.2
KP 38/18	52	52
KP 60/6	87	82
KP 60/12	107	103
KPA 40/20	56	



Pipeline & Heating Solutions



INSTRUCTIONS FOR INSTALLATION AND MAINTENANCE

ACTIVE DRIVER M/M 1.1

ACTIVE DRIVER M/T 1.0

ACTIVE DRIVER M/T 2.2

ACTIVE DRIVER T/T 3.0

ACTIVE DRIVER T/T 5.5



ACTIVE DRIVER M/M 1.1
ACTIVE DRIVER M/T 1.0 - ACTIVE DRIVER M/T 2.2
ACTIVE DRIVER T/T 3.0 - ACTIVE DRIVER T/T 5.5

DECLARATION OF CONFORMITY

The Company DAB PUMPS s.p.a. – Via M. Polo, 14 – Mestrino (PD) – ITALY – under its own exclusive responsibility declares that the products listed above comply with:

- Directive on Electromagnetic Compatibility 2004/108/CE and subsequent modifications.
- Directive on Low Voltage 2006/95/CE and subsequent modifications.
- Laagspanningsrichtlijn 2006/95/CE en successievelijke wijzigingen.

Mestrino (PD), 16/05/2007

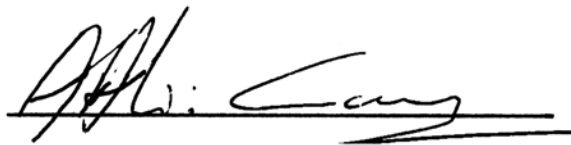
A handwritten signature in black ink, appearing to read 'Attilio Conca', is written over a solid horizontal line.

Attilio Conca
Legale Rappresentante
Legal Representative

GENERAL INDEX		page
1.	GENERAL	39
2.	WARNINGS	39
2.1	Skilled personnel	39
2.2	Safety	39
2.3	Responsibility	39
2.4	Particular warnings	39
3.	APPLICATIONS	39
4.	TECHNICAL DATA AND LIMITATIONS OF USE	40
5.	ELECTRICAL CONNECTIONS OF THE A.D. TO THE ELECTROPUMP	40
6.	CONNECTION TO THE POWER SUPPLY LINE	40
7.	HYDRAULIC CONNECTIONS	41
7.4	Risk of frost	41
8.	CHARACTERISTICS – INTERPRETATIONS – OPERATION	41
8.1	Characteristics and interpretations	41
8.2	Operation: keyboard factory settings	44
8.3	First switch-on operations (only with A.D. as accessory)	44
8.4	Operation: Parameters for the user (MODE and SET keys for 2 seconds)	45
8.4.1	SP: Setting the setpoint pressure (in bar)	45
8.5	Operation: Parameters for the installer (MODE and SET and - keys for 5 seconds)	45
8.5.1	rC: Setting the rated current of the electropump (excluding A.D. M/M 1.1)	45
8.5.2	rt: Setting the direction of rotation (excluding A.D. M/M 1.1)	45
8.5.3	Fn: Setting the rated frequency (pre-set value 50Hz)	45
8.5.4	od: Setting the operating mode of the A.D.	45
8.5.5	rP: Setting the fall in pressure for restarting	46
8.5.6	Ad: Setting the interconnection address (excluding A.D. M/M 1.1)	46
8.5.7	Eb: Enabling booster (pre-set value 2) (excluding A.D. M/M 1.1)	46
8.6	Operation: Technical Assistance displays and settings (MODE and SET and + keys for 5 seconds)	46
8.6.1	tb: Setting the reaction time of the water lack blockage	46
8.6.2	GP: Setting the gain of the proportional coefficient of the PI	46
8.6.3	GI: Setting the gain of the integral coefficient of the PI	47
8.6.4	FS : Setting the maximum rotation frequency of the electropump.	47
8.6.5	FL : Setting the minimum frequency	47
8.6.6	Ft: Setting the low flow rate threshold	47
8.6.7	CM: Method of exchange (pre-set value 1) (excluding A.D. M/M 1.1)	47
8.6.8	AE : Enabling the anti-block/anti-frost function	48
8.6.9	Setting pump start	48
8.6.10	SF : Setting the starting frequency	48
8.6.11	St : Setting the starting time	48
8.6.12	Setup of the auxiliary digital inputs IN1; IN2; IN3 with the parameters i1; i2; i3 (excluding A.D. M/M 1.1 and A.D. M/T 1.0)	48
8.6.13	Active Driver M/T 2.2 = setting the set point P1 function of input 2	49
8.6.14	O1: setting output 1 function (active alarm)(excluding A.D. M/M 1.1 and A.D. M/T 1.0) O2: setting output 2 function (pump operating)(excluding A.D. M/M 1.1 and A.D. M/T 1.0)	49
9.	DISPLAYS	49
9.1	Displays of the main values (MODE key)	49
	Fr: Display of the current rotation frequency (Hz)	49
	UP: Display of pressure (in bar)	49
	C1: Display of electropump phase current (A) (excluding A.D. M/M 1.1 and A.D. M/T 1.0)	49
	UE: Display of the version of the software with which the appliance is equipped	49
9.2	Monitor display (SET and - key for 2 seconds)	49
	UF: Display of flow	49
	ZF: Display of zero flow	49
	FM: Display of the maximum rotation frequency (Hz)	49

	tE: Display of the temperature of the power stages (°C)	49
	bt: Display of the temperature of the electronic card (°C)	49
	GS: Display of running status	49
	FF: Display of fault history (+ and - to scroll through the alarms)	49
10.	ACCESS TO MANUAL MODE OF THE MACHINE (SET and + and - keys for 5 seconds)	50
10.1	rt: setting the direction of rotation	50
10.2	Starting the electropump	50
11.	GENERAL SYSTEM RESET (MODE and SET and + and – keys)	50
12.	RESTORING THE FACTORY SETTINGS (SET and + keys)	50
13.	ERROR AND STATUS CONDITIONS	50
13.1	bL: Blockage due to water lack	51
13.2	bP: Blockage due to fault of the pressure sensor	51
13.3	LP: Blockage due to low supply voltage (excluding A.D. M/M 1.1 and A.D. M/T 1.0)	51
13.4	oF/ot : Blockage due to current overload in the output stages with temperature of the stages higher than 45°C	52
13.5	SC: Blockage due to direct short circuit between the phases of the output terminal	52
13.6	Manual reset of error conditions	52
13.7	Self-reset of error conditions	52
14.	INDICATIONS ON THE DISPLAY	53

INDEX OF TABLES

		Page
Table 4.	Technical data and limitations of use	40
Table 8.1.	Characteristics and interpretations	41
Table 8.2.	Operation: keyboard factory settings	44
Table 8.6.12	Table summarising the configuration of digital inputs IN1, IN2, IN3	48
Table 8.6.14	Assigning the parameters that associate functions with the digital outputs OUT1, OUT2	49
Table 10.	Access to manual mode of the machine: Use of the keys	50
Table 13.	Error and status conditions: Warnings in the fault log	51
	Error and status conditions: Error conditions	51
Table 13.7.	Automatic resets of error conditions	52
Table 14.	Indications on the display	53

INDEX OF FIGURES

		page
Fig. 1	Logic-functional diagram of the connections of the alarm output terminals	42
Fig. 2	Connection diagram for 2 ACTIVE DRIVERS for exchange function	42
Fig. 3	Logic-functional diagram of the connections of the user input terminals	43

1. GENERAL



Read this documentation carefully before installation. Installation and functioning must comply with the safety regulations in force in the country in which the product is installed. The entire operation must be carried out in a workmanlike manner.

Failure to comply with the safety regulations not only causes risk to personal safety and damage to the equipment, but invalidates every right to assistance under guarantee.

2. WARNINGS

2.1 Skilled personnel



It is advisable that installation be carried out by competent, skilled personnel in possession of the technical qualifications required by the specific legislation in force.

The term **skilled personnel** means persons whose training, experience and instruction, as well as their knowledge of the respective standards and requirements for accident prevention and working conditions, have been approved by the person in charge of plant safety, authorizing them to perform all the necessary activities, during which they are able to recognize and avoid all dangers. (Definition for technical personnel IEC 60634).

2.2 Safety

Use is allowed only if the electric system is in possession of safety precautions in accordance with the regulations in force in the country where the product is installed (for Italy, IEC 64/2).

2.3 Responsibility

The Manufacturer does not vouch for correct operation of the ACTIVE DRIVER or for any damage that it may cause if it has been tampered with, modified and/or run outside the recommended work range or in contrast with other indications given in this manual. The Manufacturer declines all responsibility for possible errors in this instructions manual, if due to misprints or errors in copying. The Manufacturer reserves the right to make any modifications to products that it may consider necessary or useful, without affecting the essential characteristics.

2.4 PARTICULAR WARNINGS

Before working on the electrical or mechanical part of the system, always turn off the mains voltage. Wait at least five minutes after the power supply to the machine has been switched off before opening the appliance. The condenser of the continuous intermediate circuit remains charged with dangerously high voltage even after the mains voltage has been switched off.

Only firmly wired mains connections are admissible. The appliance must be earthed (IEC 536 class 1, NEC and other relevant standards).

Mains terminals may carry dangerous voltage even when the motor is stopped.

In determined calibration conditions, after a power cut the converter may start automatically.

Pay attention: the **motor terminals U, V and W** (for the Active Driver M/M 1.1 the motor terminals **R and S**) may carry dangerous voltages even when the converter is not operating.

Do not operate the appliance in direct sunlight.

This appliance may not be used as an “EMERGENCY STOP mechanism” (see EN 60204, 9.2.5.4).

3. APPLICATIONS

The ACTIVE DRIVER is supplied already set up for installation in the following models:

- ACTIVE DRIVER M/T: fed with a single-phase line, controls electropumps with a 230V standard three-phase asynchronous motor.
- ACTIVE DRIVER M/M: fed with a single-phase line, controls electropumps with a 230V standard single-phase asynchronous motor.
- ACTIVE DRIVER T/T: fed with a three-phase line, controls electropumps with a 400V standard three-phase asynchronous motor.

4. TECHNICAL DATA AND LIMITATIONS OF USE

	A.D. M/M 1.1	A.D. M/T 1.0	A.D. M/T 2.2	A.D. T/T 3.0	A.D T/T 5.5
– Max phase current of the motor:	8,5 A	4,7 A	9,3 A	7,5 A	13,3 A
– Line voltage (+10% / -20%):	230 V single-phase	230 V single-phase	230 V single-phase	400 V three-phase	400 V three-phase
– Line frequency:	50-60 Hz	50-60 Hz	50-60 Hz	50-60 Hz	50-60 Hz
– Electropump voltage:	230 V single-phase	230V three-phase	230 V three-phase	400 V three-phase	400 V three-phase
– Weight of the unit (packing excluded):	4 Kg.	3,8 Kg.	3,8 Kg.	5 Kg.	5Kg.
– Work position:	Any position	Any position	Any position	Facing upward	Facing upward
– Max fluid temperature:	50°C	50°C	50°C	50°C	50°C
– Max working temperature:	60°C	60°C	60°C	60°C	60°C
– Max. pressure:	16 bar	16 bar	16 bar	16 bar	16 bar
– Regulating range:	from 1 to 6 bar	from 1 to 9 bar	from 1 to 15 bar	from 1 to 15 bar	from 1 to 15 bar
– Maximum dimensions (LxHxD):	22x28x18 cm	22x28x18 cm	22x28x18 cm	22x28x18 cm	22x28x18 cm
– Fluid input hydraulic coupling:	1 ¼" male	1 ¼" male	1 ¼" male	1 ¼" male	1 ¼" male
– Fluid output hydraulic coupling:	1 ½"female	1 ½"female	1 ½"female	1 ½"female	1 ½"female
– Degree of protection:	IP 55	IP 55	IP 55	IP 55	IP 55
– Protections:	– dry running – overload – excess temperature of the electronics – abnormal feeding voltages (excluding A.D. M/M and A.D. M/T 1.0) – direct short-circuit between the output phases				

5. ELECTRICAL CONNECTIONS OF THE ACTIVE DRIVER TO THE ELECTROPUMP

5.1  Ensure that all the terminals are fully tightened, **paying particular attention to the earth terminal**.

5.2 Check that all the connecting cables are in excellent conditions, with the external sheathing unbroken.

5.3 The motor of the installed electropump must comply with the data in the table in Chapter 4.

The user connected to the ACTIVE DRIVER M/M 1.1 must not exceed 8,5 A as phase current.

The user connected to the ACTIVE DRIVER M/T 1.0 must not exceed 4,7 A as phase current.

The user connected to the ACTIVE DRIVER M/T 2.2 must not exceed 9,3 A as phase current.

The user connected to the ACTIVE DRIVER T/T 3.0 must not exceed 7,5 A as phase current.

The user connected to the ACTIVE DRIVER T/T 5.5 must not exceed 13,3 A as phase current.

5.4 Connect the electropump to the output cable of the ACTIVE DRIVER, paying particular attention to the earth connection.



The incorrect connection of the earth lines to a terminal other than the earth terminal may cause irremediable damage to the whole appliance!



The incorrect connection of the power supply line on output terminals intended for the load may cause irremediable damage to the whole appliance!

6. CONNECTION TO THE POWER SUPPLY LINE

6.1 Connect the ACTIVE DRIVER to the power supply line by means of the power socket. (See values in chapter 4).

6.2 If an extension to the power cable is used the following minimum sections must be respected:

Section of each lead (mm ²)	Maximum length of the line (metres)
1.5	15
2.5	30
4	60



6.3 The ACTIVE DRIVER is already provided with current protections. If a magnetothermal switch is installed in line, it must have a max. capacity of 16A.

6.4 The connection of the line to the ACTIVE DRIVER must include the earth line. The total earth resistance must not exceed 100 Ohm.

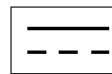
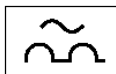
- 6.5  To protect the system it is recommended to install a differential switch with correct dimensions, type:
 Class A, with adjustable dispersion current, selective, protected against sudden tripping.
 The automatic differential switch must be marked with the following two symbols:



7. HYDRAULIC CONNECTIONS

- 7.1 Always install a check valve on the pipe upstream from the ACTIVE DRIVER.
 For the purposes of operation of the ACTIVE DRIVER it does not matter whether the valve is fitted on the suction or on the delivery of the pump.
- 7.2 The hydraulic connection between the ACTIVE DRIVER and the electropump must not have any derivations. The dimensions of the pipe must be suitable for the electropump installed.
- 7.3  The ACTIVE DRIVER works at constant pressure. This regulation is appreciated if the hydraulic system downstream from the system is of suitable dimensions.
 Systems made with pipes that have too narrow a section introduce load losses which the appliance cannot compensate; the result is that the pressure is constant on the device but not on the user.
- 7.4  RISK OF FROST: pay attention to the place where the ACTIVE DRIVER is installed!
 If the place of installation reaches a temperature below 0°C, the following precautions must be taken:
- **If the ACTIVE DRIVER is operative** it is absolutely necessary to protect it suitably against frost and to leave it constantly fed.
If it is disconnected from the power supply, the anti-frost function is no longer active!
 - **If the ACTIVE DRIVER is not operative** it is advisable to turn off the power supply, disconnect the appliance from the pipe and completely empty out all water left inside.
It is not sufficient just to remove pressure from the pipe, because some water is always left inside.

8. CHARACTERISTICS – INTERPRETATIONS – OPERATION

The ACTIVE DRIVER is an innovative integrated system for controlling electropumps with variable speed, able to keep a constant pressure while the flow rate varies.

The ACTIVE DRIVER is composed of an inverter, a pressure sensor and a flow sensor.





With the exclusion of models M/M 1.1 and M/T 1.0 the ACTIVE DRIVER is provided with 3 inputs and 2 outputs so as to be able to realise certain interface solutions with more complex installations.

Figure 1 shows the logical function diagram for the connection of the user input terminals.

Figure 2 shows the logical function diagram for the connection of the alarm output terminals.

Figure 3 shows the connection diagram for 2 ACTIVE DRIVER units, for the exchange function.

8.1 CHARACTERISTICS AND INTERPRETATIONS

Ref.	FUNCTION	
L – N SINGLE-PHASE R – S – T THREE-PHASE		Power supply line connection terminals.
		Line earth system connection terminal.
U – V – W THREE-PHASE R – S SINGLE-PHASE		Three-phase pump connection terminals.

Ref.	FUNCTION	
		Pump earth system connection terminal.
J22	1	Power supply terminal: + 12V DC – 50Am. (excluding A.D. M/M 1.1 and A.D. M/T 1.0)
	2=IN 3	Connection terminal of input i3 for general disabling command. (excluding A.D. M/M 1.1 and A.D. M/T 1.0)
	3=IN 2	Connection terminal of input i2 for selecting set point 1. (excluding A.D. M/M 1.1 and A.D. M/T 1.0)
	4	Common connection terminal I ₃ – I ₂ (excluding A.D. M/M 1.1 and A.D. M/T 1.0)
	6=IN 1	Connection terminals of input i1 for protection against dry running. (excluding A.D. M/M 1.1 and A.D. M/T 1.0)
	7	Connection terminal: 0V DC (GND). (excluding A.D. M/M 1.1 and A.D. M/T 1.0)
J14	o1	Remote alarm connection terminal. (excluding A.D. M/M 1.1 and A.D. M/T 1.0) 250 Vac – 6 A max resistive load – 3 A max inductive load
	o2	Pump operating connection terminal. (excluding A.D. M/M 1.1 and A.D. M/T 1.0) 250 Vac – 6 A max resistive load – 3 A max inductive load
J9	Connection terminals for interconnection and exchange. ATTENTION: For interconnection cables with a length of more than 1 m, it is recommended to use screened cable with the braiding connected to earth (central pin number 2) on both appliances. ATTENTION: Scrupulously respect the connection sequence between the two appliances! (excluding A.D. M/M 1.1) (see fig.2)	

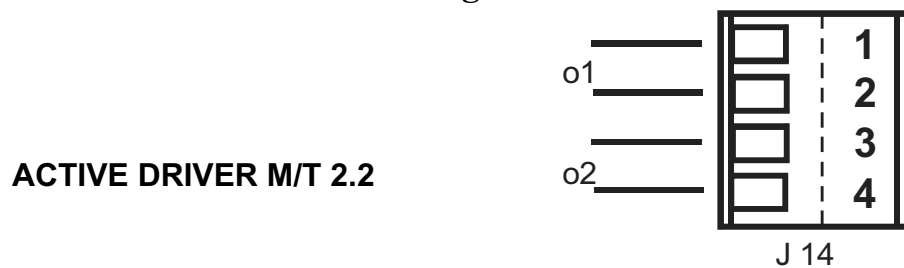
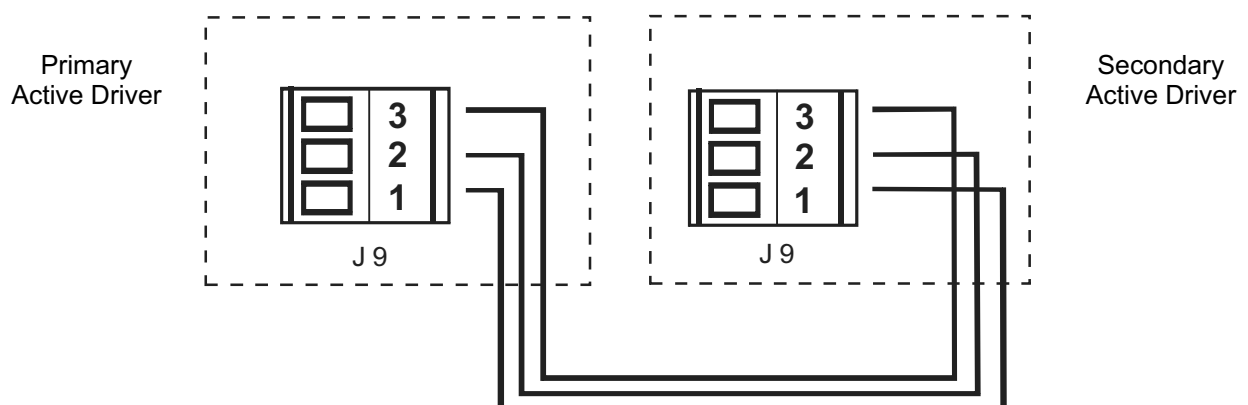
Fig. 1

Fig. 2

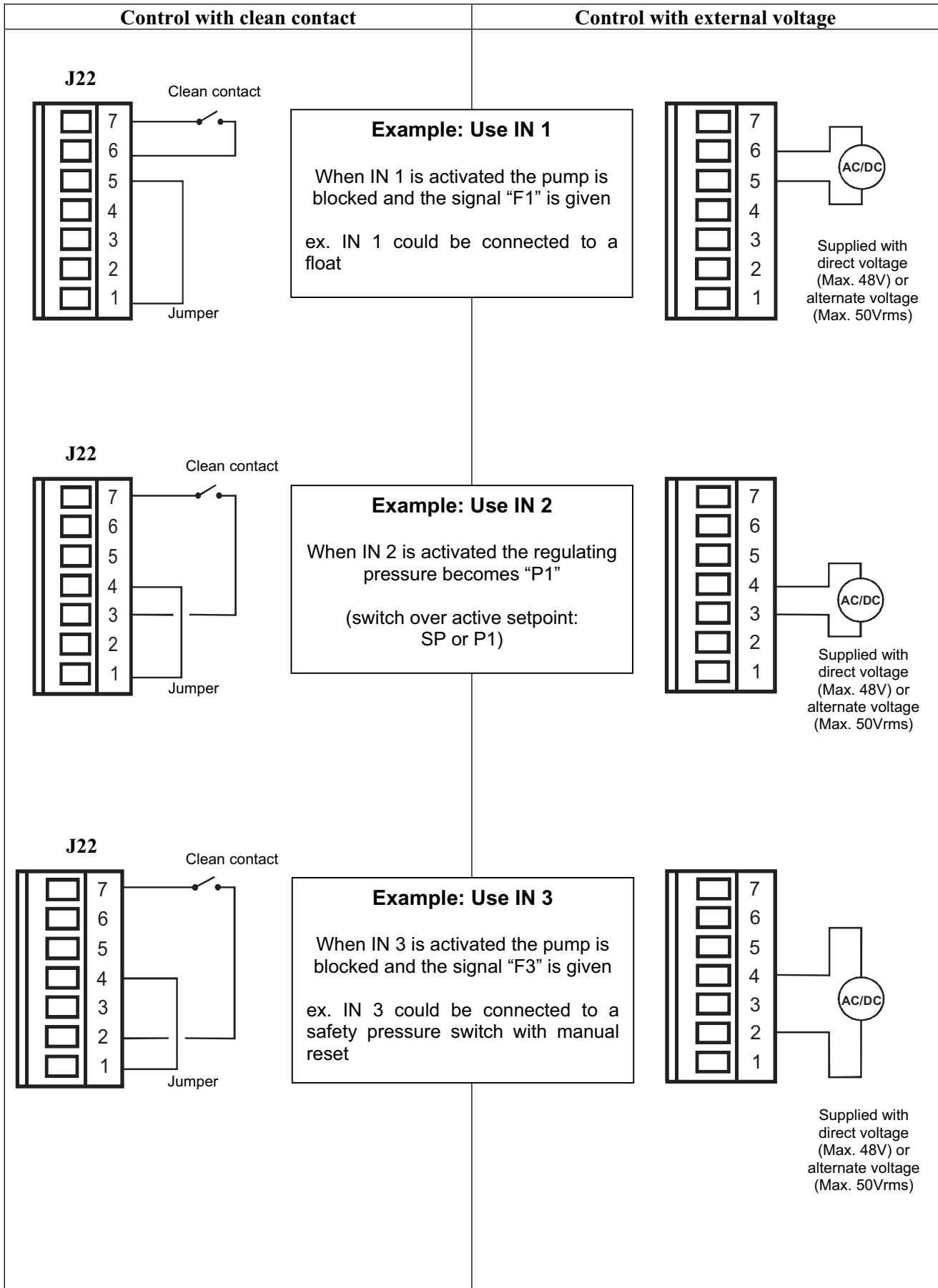
For functionality and programming:

see table on page 49 “Assigning the parameters that associate functions with the digital outputs OUT1, OUT2”

Fig. 3 – Example of possible use of the user inputs -

For functionality and programming:

see table on page 48 "Table summarising the configuration of the digital inputs IN1, IN2, IN3"

8.2 OPERATION: KEYBOARD FACTORY SETTINGS

(ref. Table no. 14 page 53)

MODE	The MODE key allows you to move on to the next items in the individual menus.
SET	The SET key allows you to quit the current menu and return to normal operating status.
+	Press to increase the currently modifiable parameter. Each time it is pressed, the value of the parameter is displayed for at least 6 seconds, after which the identifying symbol appears.
-	Press to decrease the currently modifiable parameter. Each time it is pressed, the value of the parameter is displayed for at least 6 seconds, after which the identifying symbol appears.



When the + key or the - key is pressed, the selected value is modified and saved immediately. Even the accidental shut-down of the machine during this phase does not cause the loss of the newly set parameter. The **SET** key is used only to return to the display of the machine status. It is not fundamental to press the **SET** key in order to save the changes made.

8.3 FIRST SWITCH-ON OPERATIONS (only with ACTIVE DRIVER as accessory)

(ref. Table no. 14 page 53)

After having correctly carried out the installation of the hydraulic and electric system, power can be supplied to the ACTIVE DRIVER.

The letters "ZF" will appear on the display and after a few seconds the error condition "EC" will be shown.

To start the ACTIVE DRIVER it is necessary to set the current value shown on the data plate (in A) and the frequency (in Hz) of the electropump used.

Below are described some steps for setting the main parameters and making the first start-up.

8.3.1 Setting the rated current "rC"

In normal operating status, hold down simultaneously the **MODE** and **SET** and - keys until "rC" appears on the display.

Using the + and - keys you can respectively increase and decrease the value of the parameter, according to the indications on the data plate of the electropump motor.

If the set parameter is lower than the correct one, during operation the error message "oC" will appear as soon as the set current has been exceeded for a certain time.

If the set parameter is higher than the correct one, the overload protection will trip incorrectly beyond the motor safety threshold.



An incorrect configuration of the electric motor of the electropump may cause damage to the motor.

If SET is pressed to leave the menu without setting "Fn", the set current value is activated but the ACTIVE DRIVER is not unblocked because the frequency has not been set and the letters "EC" will still be displayed.

8.3.2 Setting the rated frequency "Fn"

From the parameter "rC", press the **MODE** key once, the electropump rated frequency "Fn" will appear on the display.

The frequency "Fn" must be set as shown on the data plate of the electropump using the + and - keys.

The next time **MODE** or **SET** is pressed, the set current and frequency values are activated and the ACTIVE DRIVER is unblocked, unless other error or blocking conditions have occurred.



An incorrect configuration of the working frequency of the electropump may cause damage to the electropump.

8.3.3 Setting the direction of rotation

From the parameter "Fn" press the **MODE** key to make the current and frequency settings active and move on to the next item "rt". At this point the ACTIVE DRIVER is ready to start.

Switch on a user to start the electropump turning.

If the direction of rotation is correct, proceed to set the Setpoint pressure, otherwise invert the direction of rotation of the motor using the + and - keys (function active even with the motor switched on).

8.3.4 Setting the setpoint pressure

In normal operating status, hold down simultaneously the **MODE** and **SET** keys until "SP" appears on the display. In these conditions the + and - keys respectively allow you to increase and decrease the desired pressure value.

The regulating range is from 1 to 15 bar depending on the ACTIVE DRIVER model.

Press **SET** to return to normal operating status.

8.4 OPERATION : PARAMETERS FOR THE USER (ref. Table no. 14 page 53)

Access keys **MODE** and **SET** for 2 seconds

8.4.1 SP : Setting the set point pressure (in bar)

From normal operating status, hold down the **MODE** and **SET** keys simultaneously until the letters **SP** appear on the display. In these conditions the + and – keys allow you respectively to increase and decrease the desired pressure value.

The regulating range is from 1 to 6 bar for the S.D. M/M 1.1, from 1 to 9 bar for the A.D. M/T 1.0 and from 1 to 15 bar for the other models.

Press **SET** to return to normal operating status.

As well as the working pressure the ACTIVE DRIVER allows you to set one other value:

rP: expresses in bars the decrease in pressure, with respect to SP, that makes the pump restart.

8.5 OPERATION : PARAMETERS FOR THE INSTALLER (ref. Table no. 14 page 53)

Access keys **MODE** and **SET** and – for 5 seconds



If an error or malfunction occurs during this phase, the display is not changed. Depending on the type of error, the electropump may switch off. However it is still possible to make the desired calibration. To know the type of error that has occurred you must return to the mode in which you see the operating status by pressing the SET key.

From normal operating status, hold down the **MODE** and **SET** and – keys simultaneously until the letters “rC” appear on the display. In these conditions the + and – keys allow you respectively to increase and decrease the value of the parameter while the **MODE** key allows you to move on to the next parameter in cyclic mode. Press **SET** to return to normal operating status.

8.5.1 rC : Setting the rated current of the electropump (excluding A.D. M/M 1.1)

This parameter must be set the same as the current on the motor data plate (Amps) in the configuration in which it is used (power supply 230V for A.D. M/T - power supply 400V for A.D. T/T).

8.5.2 rt : Setting the direction of rotation (excluding A.D. M/M 1.1)

Possible values: 0 and 1

If the direction of rotation of the electropump is not correct, it is possible to invert the direction of rotation by changing this parameter.

If it is not possible to observe the direction of rotation of the motor, proceed as follows:

- Open a user and observe the frequency (parameter Fr with MODE key from GO) and the current (parameter C1).
- Without changing the amount of water taken, change the parameter rt and observe the frequency Fr and the current C1 again.
- The correct parameter rt is the one which, with the same amount of water taken, requires a lower frequency Fr and current C1.

8.5.3 Fn : Setting the rated frequency (pre-set value 50Hz)

This parameter defines the rated frequency of the electropump and it may be set at 50Hz or 60Hz.



However the frequency must be set as indicated on the data plate of the electropump motor.

Press the + or – keys to select the two frequencies 50Hz or 60Hz.



An incorrect setting of the rated frequency may cause damage to the electropump.

Each change of Fn is interpreted as a change of system and so FS, FL and FP will automatically assume the default values.

8.5.4 od: Setting the operating mode of the ACTIVE DRIVER

Possible values: 1 and 2

The ACTIVE DRIVER leaves the factory in mode 1 for working without expansion vessels or with small vessels. If there is an expansion vessel near the ACTIVE DRIVER, with a half-inch or larger fitting, you must change to mode 2.

8.5.5 **rP: Setting the fall in pressure for restarting**

Expresses, in bars, the fall in pressure that makes the pump restart.

rP may be set from a minimum of 0.1 to a maximum of 1.5 bar.

rP is equipped with a limiting system depending on the combination of the SP value so as to have in any case a minimum restarting pressure of 0.3 bar.

8.5.6 **Ad : Setting the interconnection address (excluding A.D. M/M 1.1)**

With the ACTIVE DRIVER system it is possible to realise booster sets composed of two elements communicating by means of serial interconnection (see fig.3). In this type of installation it is necessary for the two units to have a different identifying address (Ad).

The admissible values are: “- -”, 1 and 2:

- When “Ad” is “- -” the communication is disabled.
- When “Ad” is “1” it is called Secondary ACTIVE DRIVER (booster).
- When “Ad” is “2” it is called Primary ACTIVE DRIVER (leader).

Attention: If two interconnected ACTIVE DRIVER units are set with the same “Ad” value, the communication does not work and there may be malfunctions in regulation.

When the communication does not work (due to incorrect setting of the “Ad” value, for wiring problems, or other reasons), the two ACTIVE DRIVER units will work as though they were two completely independent machines, but they will indicate the impossibility of dialogue by making the display blink when the states “Go” or “Sb” are shown.

When the “Ad” values are correctly set, some regulating parameters are aligned. In particular the secondary ACTIVE DRIVER copies the following values from the primary ACTIVE DRIVER:

- SP : Setting of the set point pressure.
- rP : Setting of the restarting pressure drop.
- Eb : Enabling of the booster pump.
- CM : Method of exchange.
- dP : Setting of the pressure differential at low flow rates.
- P1 : Setting of the input function 2 set point P1.

Note: During operation it is possible to change all the parameters of the ACTIVE DRIVER on each of the two machines.

8.5.7 **Eb : Enable booster (pre-set value 2) (excluding A.D. M/M 1.1)**

When two ACTIVE DRIVER units are interconnected with each other, in the case where only one ACTIVE DRIVER is not able to satisfy the user, there is the possibility of activating the two electropumps at the same time.

Eb = 1 : The leader-booster operating mode is disabled, so only one electropump at a time will be active.

If during operation the leader electropump is not able to satisfy the user, the booster electropump will not be switched on.

Eb = 2 : The leader-booster operating mode is enabled, so 2 electropumps can be activated at the same time.

If during operation the leader electropump is not able to satisfy the user, the booster electropump will also be switched on and will work at the maximum frequency, while the leader machine will continue to modulate the rotation frequency according to the user.

8.6 **OPERATION : TECHNICAL ASSISTANCE DISPLAYS AND SETTINGS**

Access keys **MODE** and **SET** and **+** for 5 seconds

(ref. Table no. 14 page 53)

8.6.1 **tb: Setting the reaction time of the water lack blockage**

The setting of the reaction time of the water lack blockage allows you to select the time (in seconds) taken by the ACTIVE DRIVER system to indicate the lack of water in the electropump. The variation of this parameter may be useful if it is known that there is a delay between the moment in which the electropump is switched on and the moment in which it actually starts delivering.

8.6.2 **GP: Setting the gain of the proportional coefficient of the PI**

For nearly all systems, the GP parameter set in the factory is the optimum one. However, if there should be any problems in regulation, this setting may be adjusted. Indicatively it may be said that, for example, the presence of great swings in pressure or of a slow response of the system to variations in pressure may be compensated by high GP values. Instead the occurrence of “vibrations” in pressure (extremely rapid pressure swings around the set point value) may be attributed to too high a GP value.

8.6.3 **GI: Setting the gain of the integral coefficient of the PI**

The integral value must be increased when the system is not very elastic, that is where there is absence of any expansion. On the contrary, in systems with deformable pipes or with delays due to considerable distances between the electropump and the ACTIVE DRIVER, the integral value must be lowered.



To obtain satisfactory pressure regulations, you generally have to adjust both GP and GI. In fact it is the correct agreement between these two parameters which allows the optimum pressure regulation.

8.6.4 **FS : Setting the maximum rotation frequency of the electropump.**

The ACTIVE DRIVER allows the electropump to be fed for short periods at a frequency higher than the rated frequency, limiting the maximum frequency sent to the electropump in the event of an excessive increase in temperature.

The value of the set maximum frequency (FS) can therefore be reached with the motor cold and it decreases to F_n (rated frequency) as the temperature rises in the windings.

The ACTIVE DRIVER also allows a maximum working frequency to be set that is lower than the rated frequency F_n . In this case, in whatever regulating condition, the electropump will never be run at a frequency higher than the set rated frequency.

The maximum FS is $F_n + 20\%$, while the minimum FS is $F_n - 20\%$.

FS will align automatically with F_n whenever a new F_n is set.



When increasing the supply frequency, pay attention not to exceed the Max. phase current of the motor, otherwise there is a risk of blockage due to current overload in the output stages of F.

8.6.5 **FL : Setting the minimum frequency**

FL is used to set the minimum frequency at which the electropump is to be run.

The minimum value may be assumed to be 0Hz, the maximum value is 60% of F_n .

For example, if $F_n=50\text{Hz}$, FL may be regulated between 0Hz and 30Hz.

FL will align automatically with F_n whenever a new F_n is set.

8.6.6 **Ft: Setting the low flow rate threshold**

The ACTIVE DRIVER system possesses a flow sensor. Whenever the electropump is switched off a new zero is acquired. The ACTIVE DRIVER switches off the electropump when the flow rate reading is lower than 0 flow (ZF) + the set Ft parameter.

8.6.7 **CM : Method of exchange (pre-set value 1) (excluding A.D. M/M 1.1)**

When two ACTIVE DRIVER units are interconnected to work in exchange it is possible to choose between two different strategies for alternating the switching on of the two electropumps.

CM = 0 : The primary ACTIVE DRIVER is always the regulation leader and the secondary ACTIVE DRIVER will be active as a booster (if $E_b=2$) or as a reserve (if $E_b=1$). If the secondary machine remains unused for 23 hours, it becomes the leader until it has accumulated one minute of regulation.

If during operation the leader electropump is unable to satisfy the user and the secondary electropump is set as a booster ($E_b=2$), the latter will work at maximum frequency, while the leader ACTIVE DRIVER will continue to modulate the rotation frequency according to the user.

If the user decreases, the booster machine is switched off, while the leader machine continues regulating.

CM = 1 : The primary and secondary ACTIVE DRIVER alternate in being the regulation leader. The exchange takes place each time the leader ACTIVE DRIVER goes into stand-by mode or after 2 hours of continuous activity.

If during operation the leader electropump is unable to satisfy the user and the secondary electropump is set as a booster ($E_b=2$), the latter will work at maximum frequency, while the leader ACTIVE DRIVER will continue to modulate the rotation frequency according to the user.

If the user decreases, the leader machine goes into stand-by and becomes the booster (off), while the booster machine becomes the leader (and starts regulating at variable speed).

For each of the two exchange modes, if one of the machine breaks down, the other becomes the leader and carries out regulation at constant pressure up to its maximum available power.

8.6.8 AE : Enabling the anti-block/anti-frost function

It starts rotation of the motor-impeller assembly so as to avoid mechanical blockages due to low temperature or to long inactivity. When the function is enabled, if the ACTIVE DRIVER measures a temperature that is too low and with a risk of frost, it automatically starts to turn the electropump at a low number of revs (25Hz). Instead, if the temperature is within a safety range and the ACTIVE DRIVER records long inactivity, to avoid blockages of formations of residue it makes the electropump perform an unblocking cycle every 23 hours.

ATTENTION: Since a starting frequency close to the rated value is necessary for a certain time in order to ensure the starting of a single-phase pump, whenever the anti-frost function starts up with the users closed there may be an increase in the pressure of the system.



It is important to ensure that the electropump installed has a maximum head that the system can withstand. Otherwise it is advisable to deactivate the anti-frost function.

8.6.9 Setting pump start

The minimum frequency at which a single-phase pump can be started is an extremely variable parameter, depending on the pump model used. It has therefore been made possible to set the starting frequency and the time during which that frequency must be maintained in order to guarantee the correct operation of any model. The pre-set values of SF and St are a good compromise, but if the pump does not start, or starts with difficulty or slowly, increase SF or St until good pump operation is reached. If there are problems of excess pressure at starting, it will instead be necessary to decrease the SF or St parameters. In this case it is recommended to vary one parameter at a time in small steps and to check operation. The phenomenon of excess pressure at starting is typically found only for very low SP vales (1.0-1.5 bar) and it may be limited, but not completely eliminated, by decreasing the parameters indicated above.

8.6.10 SF : Setting the starting frequency

This is the frequency at which the pump has to be started for the time St.

The pre-set value is 45 Hz and it may be varied between Fn and Fn-50% using the “+” and “-“ keys.

If a FL higher than Fn-50% has been set, SF will be limited to the value of the minimum frequency FL.

For example, for Fn=50 Hz and FL=0, SF may be set between 50 and 25 Hz; instead, if Fn=50 Hz and FL=30 Hz, SF may be set between 50 and 30 Hz.

8.6.11 St : Setting the starting time

The parameter St represents the period of time during which the frequency SF is supplied before passing the frequency control to the automatic system PI. The pre-set value of St is 1 second and it is the best value in the majority of cases. However, if necessary, the parameter St may be varied from a minimum of 0 seconds to a maximum of 3 seconds.

8.6.12 Setup of the auxiliary digital inputs IN1; IN2; IN3 with the parameters i1; i2; i3 (excluding A.D. M/M 1.1 and A.D. M/T 1.0)

The function assigned to each of the digital inputs IN1; IN2; IN3 may be activated or modified by means of the parameters i1; i2; i3.

The setup of the parameters i1,i2,i3 may always assume the values:

0 => function disabled

1 => function active on high active input (see fig.3)

2 => function active on low active input (see fig.3)

ATTENTION: the parameter i3 alone may also assume the values 3,4 and 5 (as indicated in the table)

Table summarising the configuration of the digital inputs IN1, IN2, IN3							
	Parameter	Value					
		0	1	2	3	4	5
With the intervention of the command the system goes into block and alarm status with indication F1 on the display.	i1	Each function is disabled F1 never appears.	Protection against dry running With input IN1 closed.	Protection against dry running With input IN1 open.	--	--	--
With the intervention of the command the active set point = P1.	i2	Each function is disabled F2 never appears.	Active set point =P1 With input IN2 closed.	Active set point =P1 With input IN2 open.	--	--	--
With the intervention of the command the ACTIVE DRIVER is deactivated with indication F3 on the display.	i3	Each function is disabled (default) F3 never appears.	ACTIVE DRIVER disabled With input IN3 closed.	ACTIVE DRIVER disabled With input IN3 open.	ACTIVE DRIVER disabled. With input IN3 closed + eliminate blockages and reset.	ACTIVE DRIVER disabled. With input IN3 open + eliminate blockages and reset.	Eliminate blockages and reset.

8.6.13 ACTIVE DRIVER M/T 2.2 (excluding A.D. M/M 1.1 e A.D. M/T 1.0)
Setting the set point P1 function of input 2

When the parameter i2 is set at a value other than zero, with the input 2 it is possible to select one of the two settable set points. The first is SP. The second is P1. The regulating range is from 1 to 9 bar.

8.6.14 O1: Setting output 1 function (“active alarm”) (excluding A.D. M/M 1.1 and A.D. M/T 1.0)
O2: Setting output 2 function (“pump operating”) (excluding A.D. M/M 1.1 and A.D. M/T 1.0)
Assigning the parameters that associate functions with the digital outputs OUT1; OUT2

Assigning the parameters	Value			
	0	1	2	3
o1	Each function is disabled. Contact always open	Each function is disabled. Contact always closed	In case of blocking errors the contact closes (default)	In case of blocking errors the contact opens
o2	Each function is disabled. Contact always open	Each function is disabled. Contact always closed	When the electropump is operating the contact closes (default)	When the electropump is operating the contact opens

9. DISPLAYS
9.1 DISPLAYS OF THE MAIN VALUES

(ref. Table no. 14 page 53)

Access key MODE

From normal operating status, pressing the **MODE** key displays the following values:

Fr: Display of the current rotation frequency (in Hz).

UP: Display of pressure (in bar).

C1: Display of the phase current of the electropump (in A).

(excluding A.D. M/M 1.1 and A.D. M/T 1.0)

UE: Display of the version of the software with which the appliance is equipped.

9.2 MONITOR DISPLAYS

(ref. Table no. 14 page 53)

Access keys SET and – for 2 seconds

From normal operating status, pressing the key **SET** and – enters the **MONITOR** function where the following values are displayed:

(NB: to scroll through the values press the MODE key)

UF: Display of the flow

Display of the instantaneous flow.

Parameter to be used only as a reference in programming.

ZF: Display of zero flow

Display of the reading of the flow sensor on which zero was acquired (with electropump switched off).

During normal operation the **ACTIVE DRIVER** will use this parameter to switch off the electropump.

FM: Display of the maximum rotation frequency (in Hz)

tE: Display of the temperature of the power stages (in °C)

bt : Display of the temperature of the electronic card (in °C)

GS: Display of running status

SP = pump operating to maintain pressure “SP”.

P1 = pump operating to maintain pressure “P1” (input 2 active).

AG = pump operating for “anti-frost”.

FF: Display of fault history (+ and – to scroll through the alarms)

There is a queue of 16 positions for containing the last 16 faults which have occurred during system operation. By pressing the – key you can go back in history and stop at the oldest fault present, whereas by pressing the + key you can go forward in history and stop at the most recent fault present.

The decimal point identifies the last fault to have occurred in chronological order.

The history contains at the most 16 positions. Each new fault is inserted in the most recent position (decimal point). For each fault after the sixteenth, the oldest one in the queue is erased. The history of the faults is never erased but only updated as new faults occur. Manual reset and switching off of the appliance do not erase the history of faults.

10. ACCESS TO MANUAL MODE OF THE MACHINE

(ref. Table no. 14 page 53)

 Access keys **SET** and **+** and **-** for 5 seconds

During this phase all the controls and protection systems of the **ACTIVE DRIVER** are disabled!

Use of the keys	
Keys pressed	Action
SET and + and -	Press them together for a few moments until the display shows MA
+	Increases the frequency and rotation of the electropump
-	Decreases the frequency and rotation of the electropump
MODE	Moves on to the next item in the following menu FP = Setting of the test frequency in manual mode (Hz) ≤ at the set FS value UP = Display of pressure (bar) C1 = Display of the electropump phase current (A) rt = Setting of the direction of rotation UF = Display of flow ZF = Display of zero flow
MODE and -	The electropump runs at the set frequency as long as the keys are held down
MODE and - and + (for 2 seconds)	The electropump remains operating at the set frequency. The electropump may be switched off by pressing SET (when SET is pressed a second time it takes you out of the Manual Mode menu).
SET and -	Changes the direction of rotation of the electropump (active only with the pump running).
SET	Press to stop the electropump or to leave manual mode.

10.1 rt : setting the direction of rotation

In manual mode, irrespective of which heading you are under, you can always invert the direction of rotation by simultaneously holding down the **SET** and **-** keys for 2 seconds, this command is active only with the pump running.

10.2 Starting the electropump .

Pressing the **MODE** and **-** and **+** keys simultaneously stops the electropump at the frequency FP.

The running status remains until the **SET** key is pressed.

When the electropump is ON the display blinks quickly.

When the electropump is OFF the display blinks slowly.

In manual mode, pressing the **SET** key takes you out of the menu, but if the electropump has been started, pressing the key stops only the electropump; when the electropump is stopped, pressing **SET** takes you out of the menu.

11. GENERAL SYSTEM RESET

(ref. Table no. 14 page 53)

 Access keys **MODE** and **SET** and **+** and **-**

To restart the appliance without disconnecting the power supply press the 4 keys simultaneously.

MODE and **SET** and **+** and **-**

12. RESTORING THE FACTORY SETTINGS

(ref. Table no. 14 page 53)

 Access keys **SET** and **+**
for 2 seconds when switching on

The factory settings are indicated in table no. 14 on page 53.

To reset the factory values:

Switch off the appliance, press and hold down the **SET** and **+** keys while switching on the appliance again, release the two keys only when the letters EE appear. In this case the **ACTIVE DRIVER** restores the factory settings. When it has finished setting all the parameters the **ACTIVE DRIVER** returns to normal operation.



In this phase, in the models in which RC is active, the motor current is set at 0 as factory default, so when you try to start the electropump it will immediately give the error EC. Go to the installer's display and settings menu (keys **MODE and **SET** and **-** for 5 seconds) and set the correct motor data plate current (parameter rC as in paragraph 8.5.1.)**

13. ERROR AND STATUS CONDITIONS

(ref. Table no. 14 page 53)

The **ACTIVE DRIVER** is equipped with protection systems to preserve the pump, the motor, the supply line and the **ACTIVE DRIVER** itself.

If one or more protections trip, the one with the highest priority is immediately notified on the display.

Depending on the type of error the electropump may switch itself off, but when normal conditions are restored the error status may be cancelled immediately or only after a certain time, following an automatic reset.

In cases of blockage due to water lack (bL), blockage due to current overload in the electropump (oC), blockage due to current overload in the output stages (oF), blockage due to direct short circuit between the phases of the output terminal (SC), you may try to exit the error conditions by pressing the + and – keys simultaneously. If the error condition remains, you must take steps to eliminate the cause of the malfunction.

In the case of excess temperature, the protection intervenes in two ways:

- blockage on reaching too high a temperature,
- limitation of the maximum frequency as the temperature rises.

Another type of protection is adopted on:

- the power device,
- the supply capacitors,
- the printed circuit.

These protections intervene when a potentially dangerous temperature is reached, limiting the maximum rotation frequency FS to small steps.

Once the alarm is over the protection is automatically disabled and normal operating conditions are restored. The invention of one of these three protections or a combination of them may at the most decrease the frequency FS by 20%.

The three protection systems do not cause and do not generate an error message, but they keep a trace of their intervention by generating a warning in the fault log.

If the temperature on the final output stages or on the printed circuit is not limited with this system, the blockage for excess temperature will intervene.



During the intervention of these protections a rotation frequency FR less than the expected one may be displayed.

Warning in the fault log	
Display indication	Description
Lt	Warning due to intervention of protection system on power devices
LC	Warning due to intervention of protection system on capacitors
Lb	Warning due to intervention of protection system on printed circuit

Error conditions

Error and status conditions

Display indication	Description
bL	Blockage due to water lack
bP	Blockage due to absence of pressure sensor
LP	Blockage due to low supply voltage
HP	Blockage due to high rectified voltage
ot	Blockage due to overheating of the power stages
ob	Blockage due to overheating of the printed circuit
oC	Blockage due to current overload in the electropump motor
oF	Blockage due to current overload in the output stages
oF/ot	Blockage due to current overload in the output stages with temperature of the stages higher than 45°C
SC	Blockage due to direct short circuit between the phases of the output terminal
EC	Blockage due to non setting of the rated current (rC) or of the rated frequency (Fn)
E0...E7	Blockage due to internal error 0...7
F1	Blockage due to input 1 status
F3	Blockage due to input 3 status

13.1 bL : Blockage due to water lack

In conditions of zero flow the system switches off the pump. If, by mistake, a pressure set-point is set which is higher than the maximum pressure that the electropump can supply, the system indicates “blockage due to water lack” (bL) even if there is really no lack of water. Then you must lower the switch-off pressure to a reasonable value that normally does not exceed 2/3 of the head of the installed electropump.

13.2 bP : Blockage due to fault of the pressure sensor

If the ACTIVE DRIVER is unable to detect the presence of the pressure sensor, the electropump remains blocked and the error signal “bP” is given. This status begins as soon as the problem is detected and ends automatically 10 seconds after correct conditions have been restored.

13.3 LP :Blockage due to low supply voltage (excluding A.D. M/M 1.1 and A.D. M/T 1.0)

When the line voltage at the supply terminal falls below 180V, the ACTIVE DRIVER goes into block status due to low line voltage. This is reset only automatically when the voltage at the terminal rises above 200V.

If the dimensions of the wiring are not suitably large, this block may occur when the electropump is started even if higher voltages are measured with the machine in stand-by mode.

13.4 oF/ot: Blockage due to current overload in the output stages with temperature of the stages higher than 45°C

The letters “oF” and “ot” are shown alternately on the display, indicating that a current higher than the safety threshold has been detected in the output stages and that the temperature of the stages is higher than 45°C. This means that it might be possible to restart the electropump once the stages have cooled down. The operating principle of this protection is as follows: since single-stage pumps are characterised by a high starting current, to make it possible to protect the stages both at starting and during normal operation, 2 different protection thresholds have been introduced.

Moreover, the protection threshold for starting decreases as the temperature of the output stages increases, so that it will be easier to have a blockage for current overload when trying to start a single-phase pump when the stages are too warm.

13.5 SC : Blockage due to direct short circuit between the phases of the output terminal

The ACTIVE DRIVER is equipped with protection against the direct short circuit which may occur between the phases U, V, W of the “PUMP” output terminal. When this block status is indicated, you are advised to eliminate the short circuit and to check the wiring carefully to ensure it is unbroken and the installation in general. Once these checks have been made you can try to reset operation by simultaneously pressing the + and – keys; **anyway, this will have no effect until 10 seconds have passed from the moment in which the short circuit occurred.**

Whenever a short circuit occurs, an event counter is increased and saved in the permanent memory (EEPROM).

AFTER THE HUNDREDTH SHORT CIRCUIT THE MACHINE BLOCKS PERMANENTLY AND IT WILL NO LONGER BE POSSIBLE TO UNBLOCK IT!

13.6 MANUAL RESET of error condition

In error status the operator can reset the error by forcing a new attempt, pressing the + and – keys simultaneously.

13.7 Self-reset of error conditions

For some malfunctions and block conditions, the system makes attempts at automatic reset of the electropump.

The following table shows the sequences of the operations performed by the ACTIVE DRIVER for the different types of blockage.

Automatic resets of error conditions		
Display indication	Description	Sequence of automatic reset
bL	Blockage due to water lack	- An attempt every 10 minutes for a total of 6 attempts - An attempt every 1 hour for a total of 24 attempts - An attempt every 24 hours for a total of 30 attempts
bP	Blockage due to fault of the pressure sensor	- Reset 10 seconds after correct conditions return
LP	Blockage due to low supply voltage	- Reset when voltage returns to a value in the range 220V - 20% + 10%
HP	Blockage due to high voltage	- Reset when the internal voltage returns in acceptable conditions
Ot	Blockage due to overheating of the power stages	- Reset when the temperature of the power stages falls below 70°C again
OC	Blockage due to current overload	- An attempt every 10 minutes for a total of 6 attempts
oF	Blockage due to current overload in the output stages	- An attempt every 10 minutes for a total of 6 attempts
oF/ot	Blockage due to current overload in the output stages with temperature of the stages higher than 45°C	- An attempt every 10 minutes or when the temperature has fallen by 10°C. The counting of the attempts is shared with that of the blockage oF.

14. INDICATIONS ON THE DISPLAY

Identifying s.	Description	Factory parameters				
		A.D. M/M 1.1	A.D. M/T 1.0	A.D. M/T 2.2	A.D. T/T 3.0	A.D. T/T 5.5
Go	Electropump operating					
Sb	Electropump waiting					
	User displays and settings (keys MODE and SET 2 seconds)					
SP	Setting the set-point pressure (in bar). Default: 3 bar	3.0 bar	3.0 bar	3.0 bar	3.0 bar	3.0 bar
	Installer displays and settings (keys MODE and SET and – 5 seconds)					
rC	Setting the rated current of the electropump (in A)		0.0 A	0.0 A	0.0 A	0.0 A
rt	Setting the direction of rotation		00	00	00	00
Fn	Setting the rated rotation frequency of the electropump. (in Hz)	50	50	50	50	50
od	Setting the operating mode	01	01	01	01	01
rP	Setting the pressure drop for restarting (in bar)	0.5 bar	0.5 bar	0.5 bar	0.5 bar	0.5 bar
Ad	Setting the interconnection address (necessary on sets of several electropumps with exchange)		“_ _”	“_ _”	“_ _”	“_ _”
Eb	Enabling the booster		02	02	02	02
	Technical assistance displays and settings (keys MODE and SET and + 5 seconds)					
tb	Setting the reaction time of the water lack blockage (in s.)	10 s	10 s	10 s	10 s	10 s
GP	Setting the gain of the proportional coefficient of the PI	1.0	1.0	1.0	1.0	1.0
GI	Setting the gain of the integral coefficient of the PI	1.0	1.0	1.0	1.0	1.0
FS	Setting the maximum rotation frequency of the electropump (in Hz)	50	50	50	50	50
FL	Setting the minimum rotation frequency of the electropump. (in Hz)	0	0	0	0	0
Ft	Setting the low flow rate threshold	15	15	15	15	15
CM	Exchange method on sets of 2 electropumps		01	01	01	01
AE	Setting the enabling of the anti-block/anti-frost function	01	01	01	01	01
SF	Setting the starting frequency	45				
St	Setting the starting time	1.0				
i 1	Setting the function of input 1 (float)			01	01	01
i 2	Setting the function of input 2 (set point selection)			01	01	01
i 3	Setting the function of input 3 (enable)			01	01	01
P1	Setting the auxiliary setpoint pressure (in bar) - in function of input 2 -			2.5 bar	2.5 bar	2.5 bar
o1	Setting the function of output 1 (default value: 2; function: ON alarm)			02	02	02
o2	Setting the function of output 2 (default value: 2; function: ON operating)			02	02	02
	Displays of the main values (MODE key)					
Fr	Display of the current rotation frequency (in Hz)					
UP	Display of pressure (in bar)					
C1	Display of the phase current of the electropump (in A)					
UE	Display of the version of the software with which the appliance is equipped					
	DISPLAY (keys SET and – for 2 seconds)					
UF	Display of the flow					
ZF	Display of zero flow					
FM	Display of the maximum rotation frequency (in Hz)					
tE	Display of the temperature of the power stages (in °C)					
bt	Display of the temperature of the electronic card (in °C)					
GS	Display of running status					
FF	Display of the log of errors and blockages					
	Access to manual mode (keys SET and + and – 5 seconds)					
FP	Setting the test frequency in manual mode (in Hz) ≤ the set value FS	40	40	40	40	40
UP	Pressure display (in bar)					
C1	Display of electropump phase current (in A)					
rt	Setting the direction of rotation					
UF	Display of flow					
ZF	Display of zero flow					
	System reset (keys MODE and SET and + and –)					
ZF	General reset (ZF appears when leaving reset and restarting)					

14. INDICATIONS ON THE DISPLAY

Identifying s.	Description	Factory parameters				
		A.D. M/M 1.1	A.D. M/T 1.0	A.D. M/T 2.2	A.D. T/T 3.0	A.D. T/T 5.5
	Restoring the factory settings (keys SET and + for 2 seconds when switching on)					
EE	Saving and reading the factory settings on the EEPROM					
	Error and status conditions					
bL	Blockage due to water lack					
bP	Blockage due to absence of pressure sensor					
LP	Blockage due to low supply voltage					
HP	Blockage due to high supply voltage					
ot	Blockage due to overheating of the power stages					
oC	Blockage due to current overload in the electropump motor					
oF	Blockage due to current overload in the output stages					
oF/ot	Blockage due to current overload in the output stages with temperature of the stages higher than 45°C					
SC	Blockage due to short circuit in the output stages					
EC	Blockage due to non setting of the rated current (rC) or of the rated frequency (Fn)					
E0...E7	Internal error 0...7					
F1	Status / Alarm input 1					
F3	Status / Alarm input 3					



Pipeline & Heating Solutions



05/07 cod.0013.550.91

